



TGM-DZ-59-SC/SC-B-W



TGM-DZ-59-SC/SC-W-W



TGM-DZ-59-SC/SC-S-W



TGM-DZ-59-SC/SC-S-S

## FEATURES

- ▶ True's dual zone glass merchandisers combine efficient, high volume merchandising and exceptional refrigeration with an elegant curved glass front for sophisticated presentation of high end desserts and pastries.
- ▶ Factory engineered, self-contained, capillary tube system using environmentally friendly R290 hydrocarbon refrigerant that has zero (0) ozone depletion potential (ODP), & 0.02 global warming potential (GWP).
- ▶ Refrigerated section features high capacity, factory balanced refrigeration system. Standard temperature range maintains cabinet temperatures of 33°F to 41°F (5°C to 5°C), ideally suited for refrigerated bakery and cold deli products.
- ▶ Two (2) rear sliding glass doors for back access.
- ▶ Exterior - powder coated FDA black rounded front and back, solid wood sides with aluminum cover and front panels. Color options available (upcharge may apply) - white or stainless.
- ▶ Interior - powder coated FDA white over CRS material. Color options available (upcharge may apply) - black or stainless.
- ▶ Three (3) tiered levels of adjustable wire cantilever shelves that match cabinet interior color. Chrome plated wire shelves standard on stainless units.
- ▶ Curved glass front is single pane tempered glass with extra large viewing area to maximize product presentation.
- ▶ LED interior lighting provides more even lighting throughout the cabinet. Safety shielded.

## STANDARD OPTIONS

Exterior Color	Black, White, or Stainless Steel
Interior Color	Black, White, or Stainless Steel
Shelving	White, Black, Chrome, or Mezzanine

## STANDARD FEATURES

### DESIGN

- True's combination "refrigerated" and "dry" display case glass merchandiser combines efficient, high volume merchandising and exceptional refrigeration with an elegant curved glass front for sophisticated presentation of high end deli, desserts and pastries.
- Please note: If units are banked together, because of side panel, a 1/2" (13mm) gap will remain between units.

### REFRIGERATION SYSTEM

- Factory engineered, self-contained, capillary tube system using environmentally friendly R290 hydrocarbon refrigerant that has zero (0) ozone depletion potential (ODP), & 0.02 global warming potential (GWP).
- True's self-cleaning RCU technology eliminates the need to clean the condenser coil, reduces energy consumption and helps maintain the coldest temperatures and freshest product.
- High capacity, factory balanced refrigeration system that has two (2) temperature range options. Standard temperature range maintains cabinet temperatures of 33°F to 41°F (5°C to 5°C), ideally suited for refrigerated bakery and cold deli products. Optional temperature range maintains cabinet temperatures of 42°F to 65°F (5.5°C to 18.3°C), ideally suited for chocolate & wine options.
- Pull Out Condensing unit slides out for easy cleaning and maintenance.

### CABINET CONSTRUCTION

- Exterior - powder coated FDA black rounded front and back, solid wood sides with aluminum cover and front panels. Color options available (upcharge may apply) - white or stainless.
- Curved glass front and side glass panels.
- Interior - powder coated FDA white over CRS material. Color options available (upcharge may apply) - black or stainless.
- Insulation - entire cabinet structure is foamed-in-place using a high density, polyurethane insulation that has zero ozone depletion potential (ODP) and zero global warming potential (GWP).
- Welded, heavy duty steel frame rail, black powder coated for corrosion protection.
- Frame rail fitted with leg levelers.

### CURVED FRONT DISPLAY GLASS

- Curved glass front is single pane tempered glass with extra large viewing area to maximize product presentation.

### REAR DOORS

- Two (2) rear sliding glass doors for back access.
- Each door fitted with 12" (305 mm) long aluminum handle.
- Sliding doors ride on stainless steel V-channel with stainless steel bearings. Doors fit within plastic channel frame.

### SHELVING

- Six (6) adjustable heavy duty PVC coated wire shelves standard.
- Each shelf supports a maximum weight of 150 lbs. (69 kg).

### PAN CAPACITY

- Cabinet holds six (6) 18"L x 26"D (458 mm x 661 mm) display pans and eight (8) 12"L x 18"D (305 mm x 458 mm) display pans. Pans supplied by others.

### LIGHTING

- LED interior lighting, two (2) clips underneath shelf to keep wires in place. Safety shielded.

### MODEL FEATURES

- Evaporator is epoxy coated to eliminate the potential of corrosion.
- Pull out condensing unit slides out for easy cleaning and maintenance.
- Electronic temperature control.
- NSF/ANSI Standard 7 compliant for open food product. Tested and certified for performance at NSF Type II: 80°F (27°C) and 55% relative humidity.

### ELECTRICAL

- Unit completely pre-wired at factory and ready for final connection to a 115/60/1 phase, 15 amp dedicated outlet. Cord and plug set included.



115/60/1  
NEMA-5-15R

## TGM MODEL NUMBER NOMENCLATURE SYSTEM

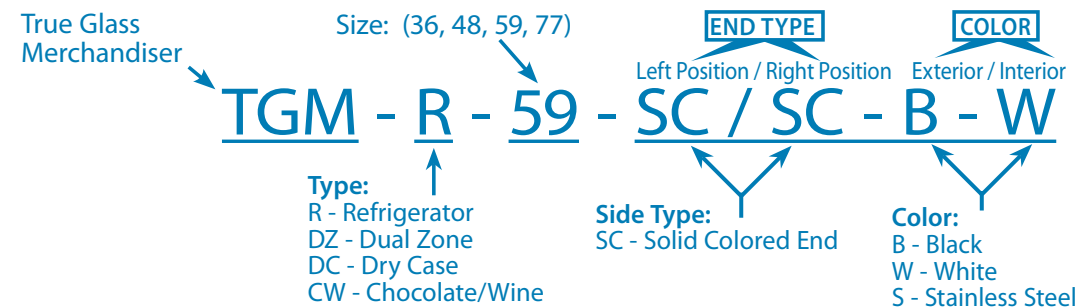

Note: Dual Zone models Not Available in 36 size models.

## PLAN VIEW

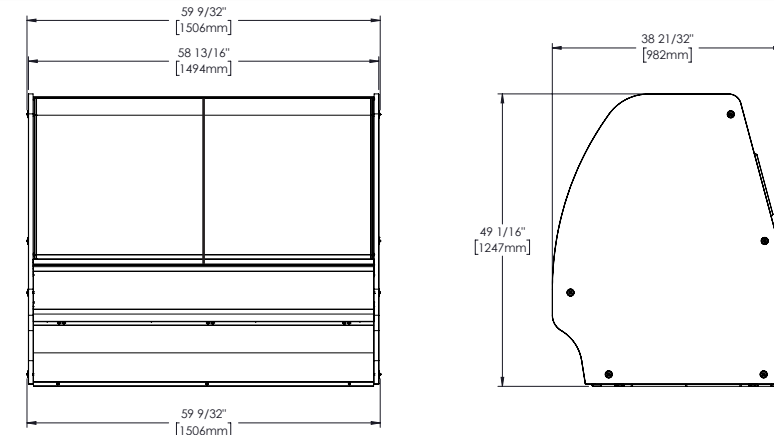

## ROUGH-IN DATA

Specifications subject to change without notice. Chart dimensions rounded up to the nearest 1/8" (millimeters rounded up to next whole number).

Model	Rear Doors	Shelves	Cabinet Dimensions (inches) (mm)			HP	Voltage	Amps	NEMA Config.	Cord Length (total ft.) (total m)	Crated Weight White/Black Model (lbs.) (kg)	Crated Weight Stainless Model (lbs.) (kg)
			W	D	H							
TGM-DZ-59-SC/SC-Δ-Δ	2	6	59 1/4 1505	39 990	49 3/8 1247	1/4	115/60/1	10.0	5-15P	9 2.74	770 350	TBD

Δ Represents Exterior/Interior (B-black, W-White, S-Stainless)

