



PROJECT NAME		LOCATION	AIA #
ITEM #	QTY	MODEL #	SIS #

SPEC SERIES®

REACH-IN GLASS SWING HALF DOOR REFRIGERATORS WITH HYDROCARBON REFRIGERANT & VERTICAL LED LIGHTING

models	STR3RVLD-6HG-HC	STA3RVLD-6HG-HC	STG3RVLD-6HG-HC
--------	-----------------	-----------------	-----------------



STR3RVLD-6HG-HC	
Exterior	Stainless steel door, front & sides.
Interior	Stainless steel side walls, back, floor, door liner, & ceiling.
Shelving	(3) Heavy duty, chrome plated, wire shelves per section.

STA3RVLD-6HG-HC	
Exterior	Stainless steel door, front & sides.
Interior	Aluminum side walls & back. Stainless steel floor & ceiling.
Shelving	(3) Heavy duty, chrome plated, wire shelves per section.

STG3RVLD-6HG-HC	
Exterior	Stainless steel door, with matching aluminum sides.
Interior	Aluminum side walls & back. Stainless steel floor & ceiling.
Shelving	(3) Heavy duty, PVC coated, wire shelves per section.

plan view

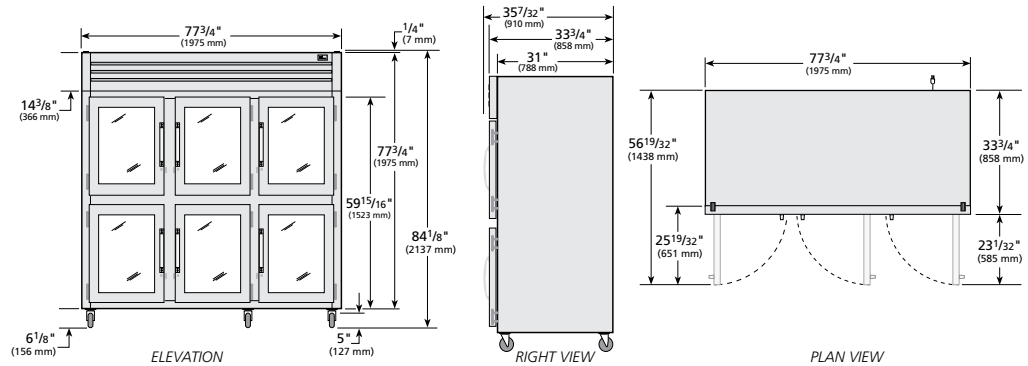

SPECIFICATIONS		
Dimensions	in.	mm.
Length	77 3/4"	1975
Depth	33 3/4"	858
Height	77 3/4"	1975
Electrical	U.S.	International
Horsepower	1/4	N/A
Amps	6.1	N/A
Voltage	115/60/1	
NEMA	5-15P	
Cord Length	9 ft.	2.74 M.
115/60/1 NEMA-5-15R		
* Height does not include 6 1/8" (156 mm) for castors or 6" (153 mm) for optional legs. † Depth does not include 1 1/2" for door handle.		

Specifications subject to change without notice.
 Chart dimensions are rounded up to the nearest 1/8" (millimeters rounded up to the next whole number).



PROJECT NAME	LOCATION	AIA #
ITEM #	QTY	MODEL #
		SIS #

SPEC SERIES®

REACH-IN GLASS SWING HALF DOOR REFRIGERATORS WITH HYDROCARBON REFRIGERANT & VERTICAL LED LIGHTING

models	STR3RVLD-6HG-HC	STA3RVLD-6HG-HC	STG3RVLD-6HG-HC
--------	-----------------	-----------------	-----------------



standard features

REFRIGERATION SYSTEM

- Factory engineered, self-contained, capillary tube system using environmentally friendly R290 hydrocarbon refrigerant that has zero (0) ozone depletion potential (ODP), & 0.02 global warming potential (GWP).
- High capacity, factory balanced refrigeration system that maintains cabinet temperatures of 33°F to 38°F (5°C to 3.3°C) for the best in food preservation.
- State of the art, electronically commutated evaporator and condenser fan motors. ECM motors operate at higher peak efficiencies and move a more consistent volume of air which produces less heat, reduces energy consumption and provides greater motor reliability.
- Top mounted refrigeration system with evaporator positioned out of food zone.
- Electronic control.

CABINET CONSTRUCTION

- Insulation - Entire cabinet structure is foamed-in-place using a high density, polyurethane insulation that has zero ozone depletion potential (ODP) and zero global warming potential (GWP).
- 5" (127 mm) diameter plate castors - locks provided on front set.

DOORS

- "Low-E", double pane thermal insulated glass.
- Lifetime guaranteed bolt style door locks.

- Lifetime guaranteed heavy duty all metal working door handles.
- Positive seal self-closing doors with 120° stay open feature. Lifetime guaranteed external cam lift door hinges, four (4) per door section.
- Magnetic door gaskets of one piece construction, removable without tools for ease of cleaning.

STANDARD SHELVING

- STR Series Shelving - (3) heavy-duty, chrome-plated wire shelves per section. Left & right section shelves are 23¹³/₁₆" L x 25⁵/₁₆" D (605 mm x 643 mm). Center section shelves are 24¹³/₁₆" L x 25⁵/₁₆" D (631 mm x 643 mm). Four (4) chrome plated shelf clips included per shelf.
- STA Series Shelving - (3) heavy-duty, chrome-plated wire shelves per section. Left & right section shelves are 23¹³/₁₆" L x 25⁵/₁₆" D (605 mm x 643 mm). Center section shelves are 24¹³/₁₆" L x 25⁵/₁₆" D (631 mm x 643 mm). Four (4) chrome plated shelf clips included per shelf.
- STG Series Shelving - (3) heavy-duty, PVC-coated, wire shelves per section. Left & right section shelves are 23¹³/₁₆" L x 25⁵/₁₆" D (605 mm x 643 mm). Center section shelves are 24¹³/₁₆" L x 25⁵/₁₆" D (631 mm x 643 mm). Four (4) chrome plated shelf clips included per shelf.

LIGHTING

- Vertical LED interior lighting mounted on interior of cabinet. Lighting runs entire length of door opening. Safety shielded.

MODEL FEATURES

- Exterior digital temperature display, available with either °F or °C.
- Evaporator epoxy coated to eliminate the potential of corrosion.
- Curb mounting ready.
- NSF/ANSI Standard 7 compliant for open food product.

ELECTRICAL

- Unit completely pre-wired at factory and ready for final connection to a 115/60/1 phase, 15 amp dedicated outlet. Cord and plug set included.

OPTIONAL FEATURES/ ACCESSORIES

(upcharge & lead times may apply)

- 6" (153 mm) standard legs.
- 6" (153 mm) seismic/flanged legs.
- 6" (153 mm) stainless steel legs.
- Grey wine shelves. (STR, STA, STG)
- Additional shelves.
- Stainless back. (STR, STA, STG)

METRIC DIMENSIONS ROUNDED UP TO THE NEAREST WHOLE MILLIMETER
 SPECIFICATIONS SUBJECT TO CHANGE WITHOUT NOTICE

	Model	Elevation	Right	Plan	3D	Back
	ST()3RVLD-6HG-HC					