



**⚠ WARNING!**



Be sure to read and fully understand this document before installing, operating, maintaining or servicing this appliance. Failure to do so can result in appliance failure, property damage, serious injury or death. Appliance failure, injury or property damage due to improper installation is not covered by warranty.

**📄 USER ACTION!**

TRUE tracks the history of your appliance by its serial number. For easy reference, record your appliances full model name and serial number below. This information is on the serial label. Serial label location varies by appliance.

**Model Name:**

**Serial Number:**

**True Manufacturing Co., Inc.**

2001 East Terra Lane • O'Fallon, Missouri 63366-4434  
(636) 240-2400 • FAX: (636)-272-2408

International FAX: (636)-272-7546 • (800)-325-6152

Parts Department: (800)-424-TRUE (424-8783)

Parts Department FAX: (636)-272-9471



**INSTALLATION MANUAL**

**Quick Start Manual**

Original Instructions

**North America – Canada and Caribbean**

Warranty Phone +1 855-878-9277  
Warranty Email [warrantyinquiries@truemfg.com](mailto:warrantyinquiries@truemfg.com)  
Technical Phone +1 855-372-1368  
Technical Email [service@truemfg.com](mailto:service@truemfg.com)  
7:00 am–6:00 pm CST Monday–Friday,  
8:00 am–12:00 pm Saturday

**Mexico**

Phone +52 555-804-6343/44  
[service-mexicocity@truemfg.com](mailto:service-mexicocity@truemfg.com)  
9:00 am–5:30 pm M–F

**Latin America**

Phone: +52 555-804-6343/44  
[servicelatam@truemfg.com](mailto:servicelatam@truemfg.com)  
9:00 am–5:30 pm M–F

**UK, Ireland, Middle East, Africa & India**

Phone: +44 (0) 800-783-2049  
[Service-emea@truemfg.com](mailto:Service-emea@truemfg.com)  
8:30 am–5:00 pm M–F

**Australia**

Phone: +61 2-9426-5222  
[service@bromicgroup.com](mailto:service@bromicgroup.com)

**European Union & Commonwealth of Independent States**

Phone: + 41 61 563 0705  
[service-emea@truemfg.com](mailto:service-emea@truemfg.com)  
8:00 am–5:00 pm M–F

**Online Resources**

Our model-specific installation manuals are updated as new information and models are released. For the latest version of your model-specific installation manual, scan the QR code below or visit our Service & Installation Manual Library at [www.truemfg.com/support/manuals/](http://www.truemfg.com/support/manuals/)



For more information regarding an appliance's temperature control adjustment or general sequence of operation, please see our *Commercial Refrigeration General Control Guide* in our resource library at [www.truemfg.com/support/manuals/#panel4](http://www.truemfg.com/support/manuals/#panel4)



For assistance locating a refrigeration service technician in your area for installation, servicing or maintenance, visit our Service Company Locator at [www.truemfg.com/support/service-locator](http://www.truemfg.com/support/service-locator) (or <https://www.truemfg.com/international/> for international support) or follow the QR codes below. TRUE is solely the appliance manufacturer and is not responsible for installation.

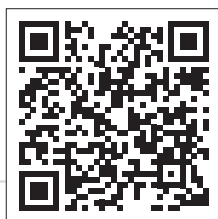

← North America

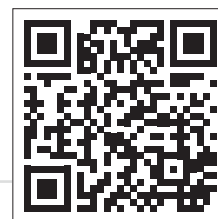

International →

# THANK YOU

## FOR YOUR PURCHASE

The primary purpose of this document is to assist the installation, maintenance, and servicing of your TRUE appliance. This document contains information important to safety, operation, maintenance, and servicing. **DO NOT** discard this document. TRUE is solely the appliance manufacturer. For assistance locating a refrigeration service technician in your area for installation, servicing or maintenance, please visit our Service Company Locator (see links and QR codes on pg. 2)

! NOTICE!	
	<p>This document supports multiple model families; for a model-specific owner's manual, please visit <a href="http://www.truemfg.com/support/manuals/">www.truemfg.com/support/manuals/</a>, follow the QR code on pg. 2, or contact TRUE's Technical Support Department.</p>

### Contents

<b>Preface</b>		<b>Appliance Operation</b>	
Signal & Symbol Definitions.....	4	Startup.....	17
<b>Important Safety Information</b>		Light Switch Location.....	18
Basic Safety & Operation Warnings.....	5	TRULUMINA® Operation.....	18
Personal Injury Warnings.....	6	General Sequence of Operation (Refrigerators & Freezers).....	19
Appliance Disposal Warnings.....	7	General Sequence of Operation (Heated Appliance).....	21
Hydrocarbon Refrigerant Warnings.....	7	Temperature Control Adjustment.....	22
Electrical Safety Warnings.....	8	<b>Maintenance &amp; Servicing</b>	
<b>About Your Appliance &amp; Installation Requirements</b>		Component Replacement.....	30
Appliance Specifications.....	9	Condenser Coil Cleaning.....	31
Clearances.....	10	General Surface Care & Cleaning.....	31
Electrical Installation.....	11	Recommended Maintenance.....	32
<b>Installation &amp; Setup</b>		<b>Warranty</b>	
Uncrate & Inspect.....	13	Warranty Information.....	35
Leveling Screw, Leg or Castor Installation.....	14		
Level the Appliance.....	15		
Seal the Appliance to the Floor.....	15		
Shelf Installation.....	15		
Remove the Protective Film.....	16		

# Preface

The warning, guidelines, and recommendations within this document are meant to prevent appliance damage, property damage, injury, or death. Please carefully read all warnings, guidelines, and recommendations before proceeding to ensure the continued safe use and maintenance of your TRUE appliance.

## Signal & Symbol Definitions

Below are symbols you may see in this document. Some symbols may not appear.

Signal Word Definitions	
<b>DANGER!</b>	An imminently hazardous situation which, if not avoided, will result in serious injury or death.
<b>WARNING!</b>	A potentially hazardous situation which, if not avoided, can result in serious injury or death.
<b>CAUTION!</b>	A potentially hazardous situation which, if not avoided, may result in minor or moderate injury; an unsafe practice.
<b>USER ACTION!</b>	User action alert, follow all recommendations to avoid appliance or product damage.
<b>NOTICE!</b>	Important information not related to hazards or risk of personal injury.

Safety Symbols	
	<b>Safety alert;</b> alerts reader to potential physical injury hazards. Obey all safety messages following this symbol to avoid possible injury or death.
	<b>Flammable material;</b> fire or explosion hazard.
	<b>Electrical shock hazard.</b>
	<b>Tipping hazard;</b> tip-over hazard.
	<b>Sharp element;</b> cut or sever hazard.
	<b>Eye hazard;</b> risk of eye injury.
	<b>Exploding pressurized cylinder hazard.</b>
	<b>Slippery surface hazard.</b>
	<b>Crush or cut hazard.</b>

Additional Symbols	
	<b>Mandatory action alert symbol;</b> alerts reader to required or recommended actions. Obey all messages and recommendations following this symbol to avoid appliance or product damage.
	<b>Important information</b> not related to hazards or risk of personal injury.
	<b>Review and understand</b> the installation manual before installing, operating, or servicing.
	Wear <b>eye protection.</b>
	Wear <b>protective gloves.</b>
	<b>Secure gas cylinders</b> to prevent falling cylinders.
	<b>DO NOT</b> use extension cord.
	<b>DO NOT</b> use adaptor plugs.
	<b>DO NOT</b> dispose of with other household waste.



**Important Safety Information**

# Important Safety Information

## Basic Safety & Operation Warnings

Follow basic safety precautions, including the following, to reduce risk of personal injury, electric shock, fire, or death.

**⚠ WARNING!**

 	<p><b>Be sure to read and fully understand this document before installing, operating, maintaining, or servicing this appliance. Failure to do so can result in appliance failure, property damage, serious injury, or death. Appliance failure, personal injury, or property damage due to improper installation is not covered by warranty.</b></p> <ul style="list-style-type: none"> <li>• Failure to install, operate, and maintain the appliance as detailed in this document will negatively affect safety, appliance performance, component life, and warranty coverage.</li> <li>• Only qualified technicians should install and service the appliance. For assistance locating a refrigeration service technician in your area for installation, servicing or maintenance, please visit our Service Company Locator (see links and QR codes on pg.2). TRUE is solely the appliance manufacturer and is not responsible for installation.</li> <li>• This appliance is not to be used, cleaned, or maintained by persons (including children) with reduced physical, sensory, or mental capabilities or lack of experience and knowledge, without proper supervision or instruction concerning the appliance by a person responsible for their safety.</li> <li>• <b>DO NOT</b> install or operate equipment that has been misused, abused, neglected, damaged, or altered/modified from original manufactured specifications.</li> <li>• <b>DO NOT</b> modify or alter the appliance.</li> <li>• <b>DO NOT</b> use electrical appliances inside the food storage compartments of the appliance unless the appliances are approved by the manufacturer.</li> <li>• The appliance owner is responsible for performing a Personal Protective Equipment (PPE) Hazard Assessment and to ensure adequate protection during maintenance and cleaning procedures.</li> <li>• Use appropriate tools, safety equipment, and PPE during installation and servicing.</li> <li>• Only use the appliance for its intended purpose as described in this document.</li> <li>• All shelving must be properly installed and adhere to load limits. Incorrect installation and improperly loaded or overloaded shelves can result in appliance damage, product damage, or personal injury.</li> <li>• Keep the area surrounding the appliance clean and dry to avoid personal injury or appliance damage from debris or pests.</li> </ul>
--	--

**📌 USER ACTION!**

	<ul style="list-style-type: none"> <li>• The appliance must be installed in accordance with all applicable laws, codes, and regulations.</li> <li>• This appliance is to be installed in accordance with the Safety Standard for Refrigeration Systems, ANSI/ASHRAE 15.</li> </ul>
---	--

**📌 NOTICE!**

	<p>The manufacturer is not responsible for injury or damage resulting from improper, incorrect, and unreasonable use.</p>
---	---

# Important Safety Information (cont.)

## Personal Injury Warnings

### ⚠ DANGER!

	<b>DO NOT</b> allow children to play with or in the appliance. Child entrapment or personal injury can occur.
	<b>DO NOT</b> store or use the following in the vicinity of this or any other appliance: <ul style="list-style-type: none"> <li>• Gasoline or other flammable vapors and liquids</li> <li>• Combustible or explosive substances, such as aerosol cans with a flammable propellant</li> <li>• Other volatile or flammable substances</li> </ul>
 	<b>Contact TRUE Manufacturing to locate refrigerant lines and electrical wiring</b> before drilling, cutting or puncturing interior or exterior walls. Failure to do so could result in damage, personal injury, or death.

### ⚠ WARNING!

	<b>Only qualified technicians should install and service the appliance. For assistance locating a refrigeration service technician in your area for installation, servicing or maintenance, please visit our Service Company Locator (see links and QR codes on pg. 2). TRUE is solely the appliance manufacturer and is not responsible for installation.</b> <ul style="list-style-type: none"> <li>• Use appropriate tools, safety equipment, and personal protective equipment (PPE) during installation and servicing.</li> <li>• <b>DO NOT</b> touch the cold surfaces in the freezer compartment when hands are damp or wet. Skin may stick to extremely cold surfaces.</li> <li>• Lifting assistance may be required during installation, servicing, and maintenance. Team lift or use a lifting device. Always use proper lifting techniques or personal injury may occur.</li> </ul>
	<b>This product can expose you to chemicals</b> including Chromium VI Compounds, which are known to the State of California to cause cancer and birth defects or other reproductive harm. For more information go to <a href="http://www.P65warnings.ca.gov">www.P65warnings.ca.gov</a> .
	<b>Slippery Surfaces!</b> Moisture from improper drainage can create slippery surfaces near the appliance. It is your duty to immediately warn your customers of, and dry, the slippery surface. All wet floor areas must be marked with a wet floor sign.
	<b>Sharp edges!</b> Take care when moving, installing, cleaning, servicing, and maintaining the appliance to avoid cuts. Be sure to take care when reaching under the appliance or handling metal components. <ul style="list-style-type: none"> <li>• Keep fingers out of pinch point areas, such as the space between appliance doors and surrounding cabinetry. Take care closing doors with children nearby.</li> </ul>
	<b>Tip over hazard!</b> Appliance may pose a tipping hazard when uncrating, installing, or moving the appliance. Take appropriate safety precautions. Use of tip over restraints may only reduce (not eliminate) the tipping hazard. Never allow children to climb or hang on drawers, doors, or shelves.
	<b>Crush or cut hazard!</b> Keep clear when uncrating, installing, moving, or servicing the appliance.
	<b>Risk of electric shock or burn!</b> See "Electrical Safety Warnings" for more information.

## Important Safety Information (cont.)

### Appliance Disposal Warnings

<b>DANGER!</b>	
	<p><b>Risk of child entrapment!</b></p> <p>Children can get trapped inside discarded appliances and suffocate. Never dispose of your appliance without taking precautions to prevent child entrapment, even if the appliance only sits unattended for a short period of time.</p> <p><b>Child entrapment precautions include the following:</b></p> <ul style="list-style-type: none"> <li>Remove all doors (or drawers for drawer appliances).</li> <li>Leave all interior drawers and shelving in place to make climbing (and fitting) inside the appliance more difficult.</li> </ul>
	<p><b>Risk of fire or explosion!</b> Flammable refrigerant and insulation used. Dispose of the appliance in accordance with all applicable laws, codes, and regulations. Follow all safety precautions associated with handling flammable refrigerant and insulation.</p>
	<p><b>DO NOT</b> dispose of your appliance with household waste.</p>



### Hydrocarbon Refrigerant Warnings

TRUE appliances use hydrocarbon refrigerant (R-290/513A/600a). Check the serial label to identify the appliance's refrigerant. Serial label location varies by model.

<b>DANGER!</b>	
	<p><b>Risk of fire or explosion! Flammable refrigerant used.</b></p> <ul style="list-style-type: none"> <li>All servicing and maintenance must be performed by qualified technicians to minimize the risk of fire or personal injury due to incorrect parts or improper service.</li> <li>Check the serial label to identify the appliance's refrigerant. Serial label location varies by model.</li> <li><b>DO NOT</b> damage the refrigeration system during transportation and installation.</li> <li>If the appliance is damaged, check the refrigeration system for damage before installing or putting into service.</li> <li>Never use sharp objects or tools to remove ice or frost. <b>DO NOT</b> use mechanical devices to accelerate defrost.</li> <li>Dispose of the appliance in accordance with all applicable laws, codes, and regulations. Follow all safety precautions associated with handling flammable refrigerant.</li> <li><b>DO NOT</b> use electrical appliances inside the food storage compartments of the appliances unless the appliances are of the type recommended by the manufacturer.</li> <li><b>DO NOT</b> use cellphones near pipes or cables, cigarettes, cigars, or vapes near the appliance as these can be a source of ignition or spark.</li> </ul>

## Important Safety Information (cont.)

### Electrical Safety Warnings

#### DANGER!

**Risk of electric shock, burn, or fire! Failure to comply with these electrical warnings may result in appliance damage, property damage, electrical shock, burns, or fire leading to serious personal injury or death.**



- It is the appliance owner's responsibility to ensure the electrical connection meets all applicable building codes.
- Before connecting the appliance to the power supply, verify the supply voltage and circuit rating match the appliance. Correct improper supply voltage or circuit size immediately.
- Before connecting the appliance to the power supply, verify the power supply is correctly grounded. If the power supply is not grounded, correct immediately. TRUE recommends hiring a qualified electrician to inspect the wall outlet and circuit to ensure they are properly grounded.
- **DO NOT** clean appliance with a pressure washer or hose. **DO NOT** immerse power cord in water.
- Always unplug the appliance or disconnect power before installation or servicing. Powering off an electronic control or setting temperature controls to 0 (off position) does not remove power from all components.
- The appliance should receive power from its own individual dedicated electrical circuit to avoid overloading the power supply.
- **The original equipment manufacturer (OEM) power cord has a grounding plug to minimize the possibility of electrical shock.**
  - **Never remove the ground prong from the power cord!** For personal safety, this appliance must be properly grounded.
  - **Never use an extension cord!** An extension cord is any component that adds length to the OEM power cord when connecting the cord to a power source.
  - **Never use an adapter plug!** An adapter plug alters the OEM plug configuration when connecting the plug to a power source.
- **Never use a power cord that shows cracks or abrasion damage along its length or at either end.**
  - Immediately have a qualified technician replace damaged OEM power cords with OEM components.
- **Never unplug the appliance by pulling on the power cord!** Always grip the plug and pull the plug straight out of the outlet.
- Take care to prevent rolling over or damaging the power cord when moving the appliance.
- **Never use the power cord to prevent appliance movement!** Always use adequate means to keep the appliance in place without transmitting stress to the power cord.
- Keep power cord away from heated surfaces.
- **DO NOT** let power cord hang over edge of table or counter.
- **DO NOT** excessively bend or place heavy articles on the power cord.

#### NOTICE!



**TRUE will not warranty the following:**

- Compressor failures due to improper incoming voltage.
- Appliance with tampered OEM power cords.
- Appliance connected to adapters or extension cords.

For more details, see TRUE's full warranty statement.

# About Your Appliance & Installation Requirements

## About Your Appliance & Installation Requirements

! USER ACTION!	
	<p><b>TRUE is not responsible for damage</b> incurred during shipment. Always carefully inspect for freight damage before receiving and installing the appliance. If there is damage, note all damage on the delivery receipt, immediately file a claim with the delivery freight carrier, and contact TRUE.</p> <p><b>Do not install the appliance or put it in service.</b></p>

Thank you for choosing TRUE Manufacturing to meet your refrigeration needs. TRUE highly recommends a qualified technician and electrician install your appliance to ensure correct installation. The cost of professional installation is money well spent. Only qualified technicians should install and service the appliance.

For assistance locating a refrigeration service technician in your area for installation, servicing or maintenance, please visit our Service Company Locator (see links and QR codes on pg. 2). TRUE is solely the appliance manufacturer and is not responsible for installation.

The appliance owner is responsible for proper installation and maintaining the appliance as described in this document. Routine care and maintenance procedures are not covered by TRUE's warranty.

### Appliance Specifications

Some things to know about your appliance are as follows:

- Appliances with doors tested for IEC to ISO Climate Class 5 (104°F (40°C) temperature, 40% relative humidity).
- Appliances with air curtains tested for IEC to ISO Climate Class 8 (75°F (24°C) temperature, 55% relative humidity).
- Appliance tested for a weighted sound pressure below 70 dB.
- Appliance is not for the storage and/or display of potentially hazardous foods when the temperature control is set above 41°F (5°C).
- Appliance is not suitable for an area where a pressure washer or hose may be used.
- Always plug the appliance into its own individual dedicated electrical circuit!
- Before connecting your appliance to the power supply, verify the incoming voltage (±5%) and the amps match the operation ratings on the appliance's serial label. Correct improper incoming voltage or amps immediately. Serial label location varies by model.
- Before connecting your appliance to the power supply, verify the power supply is correctly grounded. If the power supply is not grounded, correct immediately.
- Ensure the installation location will provide adequate clearances and sufficient airflow for the appliance. See "Clearances" (pg. 10)
- Read and follow all warnings and maintenance instructions. Failure to do so may result in damage and void the warranty on your appliance.
- For energy and performance testing, never load product on the appliance interior floor.

## About Your Appliance & Installation Requirements (cont.)

### Clearances

#### ! USER ACTION!



If your model clearances are not listed in the table, check your model specific manual at [www.truemfg.com/support/manuals/](http://www.truemfg.com/support/manuals/) or follow the QR code on pg. 2.

#### ! NOTICE!



**Warranty is void if ventilation is insufficient.** Be sure your appliance has the required surrounding clearances. Keep all ventilation openings in the appliance enclosure or structure housing the appliance clear of obstruction.

MODEL	TOP	SIDES	BACK
CVM-11/13	1" (25.4 mm)	0" (0 mm)	1" (25.4 mm)
CVM-20/24/27	0" (0 mm)	0" (0 mm)	1" (25.4 mm)
CVM Freezer	3" (76.2 mm)	0" (0 mm)	3" (76.2 mm)
Deli	N/A Open	0" (0 mm)	Open
FLM Freezer	3" (76.2 mm)	0" (0 mm)	3" (76.2 mm)
FLM Refrigerator	0" (0 mm)	0" (0 mm)	1" (25.4 mm)
G4SM	0" (0 mm)	0" (0 mm)	1" (25.4 mm)
GDIM	1" (25.4 mm)	0" (0 mm)	3" (76.2 mm)
GDM-05/05F	12" Open (304.8 mm)	1" (25.4 mm)	1" (25.4 mm)
GDM-07F	1" (25.4 mm)	1" (25.4 mm)	3" (76.2 mm)
GDM-10/12/10-58	1" (25.4 mm)	0" (0 mm)	1" (25.4 mm)
GDM-11SD	0" (0 mm)	0" (0 mm)	1" (25.4 mm)
GDM Freezer	3" (76.2 mm)	0" (0 mm)	3" (76.2 mm)
GDM Refrigerator	0" (0 mm)	0" (0 mm)	1" (25.4 mm)
GEM	0" (0 mm)	0" (0 mm)	1" (25.4 mm)

MODEL	TOP	SIDES	BACK
Glass Chillers	1" (25.4 mm)	1" (25.4 mm)	1" (25.4 mm)
Spec Series	12" Open (304.8 mm)	0" (0 mm)	1" (25.4 mm)
T-Series Freezer	3" (76.2 mm)	0" (0 mm)	3" (76.2 mm)
T-Series Refrigerator	0" (0 mm)	0" (0 mm)	1" (25.4 mm)
TAC	8" (203.2 mm)	0" (0 mm)	3" (76.2 mm)
TBB/TDD/TDB/TD	1" (25.4 mm)	1" (25.4 mm)	1" (25.4 mm)
TBR/TDR/EBR/EDR	0" (0 mm)	0" (0 mm)	0" (0 mm)
TCGG	0" (0 mm)	0" (0 mm)	Open
TCM	0" (0 mm)	1" (25.4 mm)	1" (25.4 mm)
TCR/TCF	0" (0 mm)	0" (0 mm)	0" (0 mm)
TDC	N/A Open	1" (25.4 mm)	Open
TDM/TGM	Open	1" (25.4 mm)	Open
TFM	Open	1" (25.4 mm)	1" (25.4 mm)
TFP/TFT	0" (0 mm)	0" (0 mm)	0" (0 mm)
TGN Freezer	3" (76.2 mm)	0" (0 mm)	3" (76.2 mm)
TGN Refrigerator	0" (0 mm)	0" (0 mm)	1" (25.4 mm)
THAC	0" (0 mm)	1" (25.4 mm)	1" (25.4 mm)
TMC	0" (0 mm)	0" (0 mm)	1" (25.4 mm)
TOAM	8" (203.2 mm)	0" (0 mm)	3" (76.2 mm)
TPP/TSSU	N/A	0" (0 mm)	0" (0 mm)
TRCB	1" (25.4 mm)	1" (25.4 mm)	1" (25.4 mm)
TSD-09G, GDM-09	1" (25.4 mm)	1" (25.4 mm)	1" (25.4 mm)
TUC/TWT	0" (0 mm)	0" (0 mm)	0" (0 mm)
TVM Refrigerator	0" (0 mm)	0" (0 mm)	1" (25.4 mm)
TVM-FD (Full Door)	1" (25.4 mm)	0" (0 mm)	1" (25.4 mm)

# About Your Appliance & Installation Requirements (cont.)

## Electrical Installation

### ⚠ DANGER!



- **Never use an extension cord!** An extension cord is any component that adds length to the OEM power cord when connecting the cord to a power source.



- **Never use an adapter plug!** An adapter plug alters the OEM plug configuration when connecting the plug to a power source.



- **Always use the correct outlet.** See "NEMA Plug Configurations" below.

### ! USER ACTION!



Find a copy of the wiring diagram with our serial number lookup at [www.truemfg.com/support/serial-number-lookup](http://www.truemfg.com/support/serial-number-lookup).

## NEMA Plug Configurations

### 60 HZ USE ONLY!

TRUE uses these types of NEMA plugs shown. If you **DO NOT** have the proper outlet, have a licensed electrician verify and install the correct power source.



## International (IEC) Plugs Only

International appliances may be supplied with a power cord that will require installation. Install this cord before connecting the appliance to a power source.

**NOTICE** International plug configurations will vary by country and voltage.

### Installation

Fully seat the power cord into the appliance receptacle until it locks in position. See fig. 1.

### Removal

Depress the red button. See fig. 2.

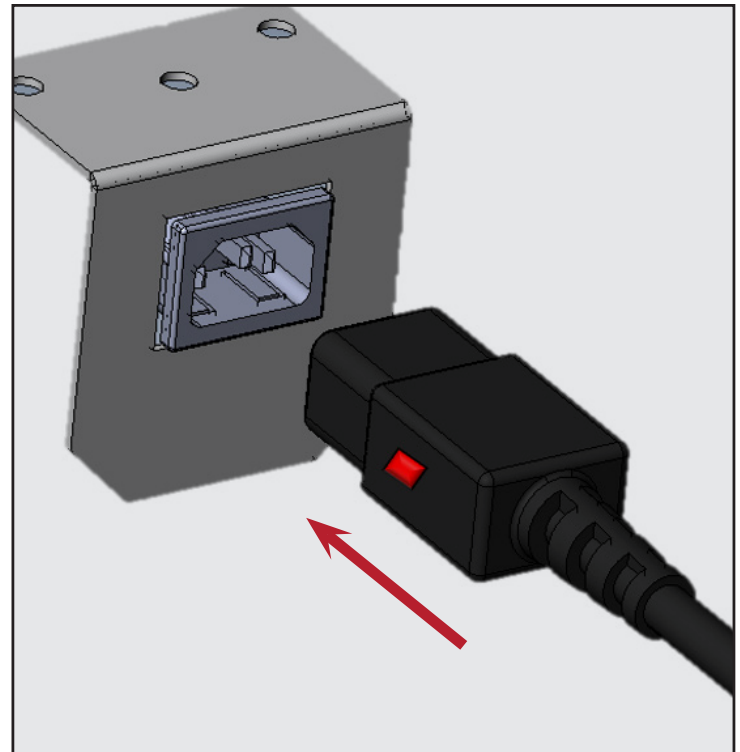

Fig. 1. Fully insert the power cord into the receptacle.

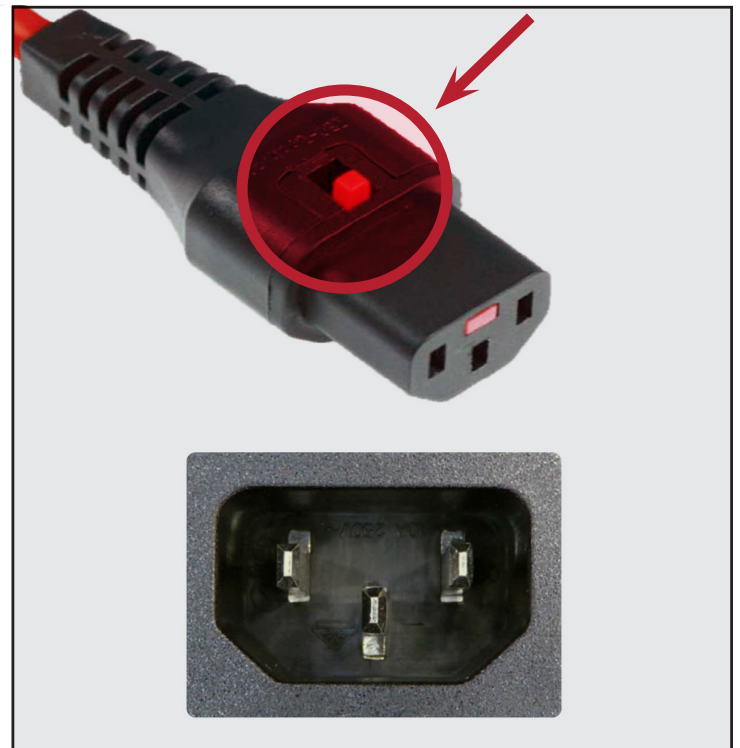



Fig. 2. Push the red button to remove the plug.



Installation & Setup

# Installation & Setup

**⚠ DANGER!**



**Risk of electrical shock or burn!** Powering off an electronic control or setting temperature controls to the 0 (off) position does not remove power from all components. Unplug the appliance or disconnect power before installation or servicing.

**⚠ WARNING!**



**Only qualified technicians** should install and service the appliance. For assistance locating a refrigeration service technician in your area for installation, servicing or maintenance, please visit our Service Company Locator (see links and QR codes on pg. 2).





**The appliance owner is responsible** for performing a Personal Protective Equipment (PPE) hazard Assessment and to ensure adequate protection during maintenance and cleaning procedures.

**Use appropriate tools**, safety equipment, and PPE during installation and servicing.



**Sharp edges!** Take care when moving, installing, cleaning, servicing and maintaining the appliance to avoid cuts. Be sure to take care when reaching under the appliance or handling metal components. Keep fingers out of pinch point areas, such as the space between appliance doors and surrounding appliances. Take care closing doors with children nearby.



**Tip over hazard!** Appliance may pose a tipping hazard when uncrating, installing or moving the appliance. Take appropriate safety precautions. Use of tip over restraints may only reduce (not eliminate) the tipping hazard. Never allow children to climb or hang on drawers, doors or shelves.



**Crush or cut hazard!** Keep clear when uncrating, installing, moving, or servicing the appliance.

**ⓘ NOTICE!**



See detailed installation information in our model-specific installation manuals; find your model specific installation manual at [www.truemfg.com/support/manuals/](http://www.truemfg.com/support/manuals/)

follow the QR code on pg. 2, or contact TRUE's Technical Support Department.

Keys for appliances with door locks are located on the back cover of this manual.

## Uncrate & Inspect

**ⓘ USER ACTION!**



- If the appliance is damaged, note all damage on the delivery receipt, immediately file a claim with the delivery freight carrier, and contact TRUE. **DO NOT install the appliance or put it in service.**
- If the appliance is laid on its back or side, be sure to leave the appliance upright twice the time it has been laying down (up to four (4) hours) before plugging the appliance into a power source. If this time exceeds four (4) hours, let the appliance sit upright for 24 hours before powering the appliance.

1. Inspect the exterior packaging for damage. Follow TRUE's recommended procedure for accepting deliveries.
2. Remove the exterior packaging. Inspect the appliance for visible or cosmetic damage.
3. Move the appliance as close to the final installation location as possible before removing the wooden skid.

## Installation & Setup (cont.)

### Leveling Screw, Leg, or Castor Installation

#### ⚠ WARNING!

**Tipping hazard! ALWAYS** verify center leveling screws fully contact the floor after leveling the appliance.

**ALWAYS** be sure leveling legs or castors (and shims) are snug against the rail assembly or mounting plate.

**ALWAYS** verify center castors or leveling legs fully contact the floor after leveling the appliance. See fig. below.

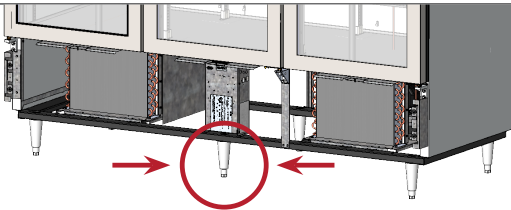

**Sharp edges!** Take care when moving, installing, cleaning, servicing and maintaining the appliance to avoid cuts. Be sure to take care when reaching under the appliance or handling metal components.

Leveling screws assist the leveling of the appliance. Adjustable legs provide 6" (153 mm) of clearance under appliance. Castors provide appliance mobility. Always use shims when adjusting castors.

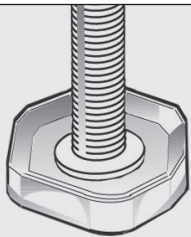

Fig. 1. Leveling screw.

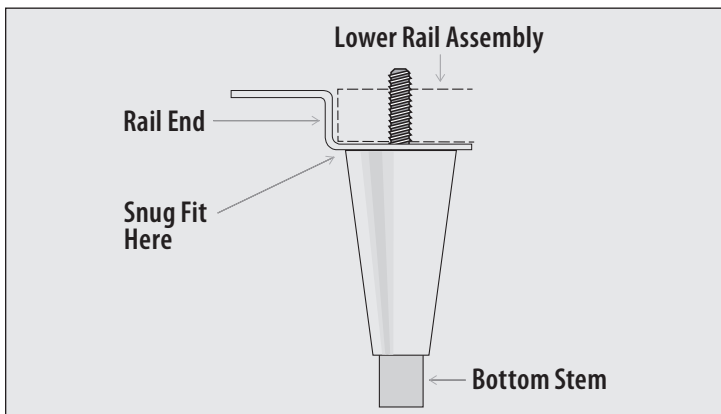

Fig. 2. Parts of an adjustable leveling leg. Adjust the bottom stem to level appliance.

#### ⓘ USER ACTION!



Install castors with brakes in the front.

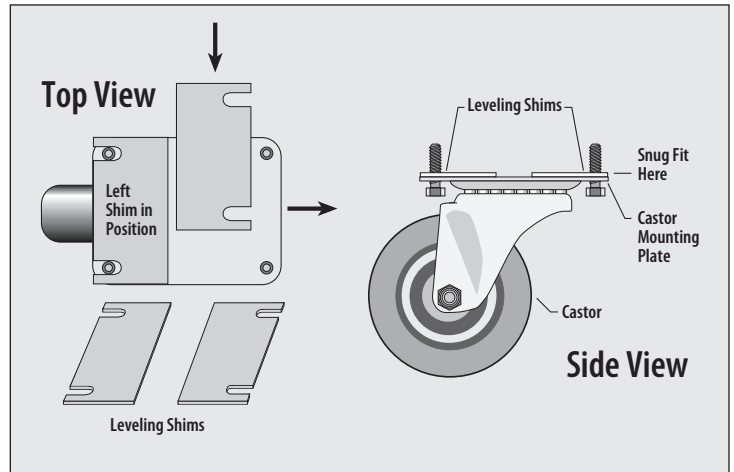

Fig. 3. Platform castor and shims. Install shims in pairs.

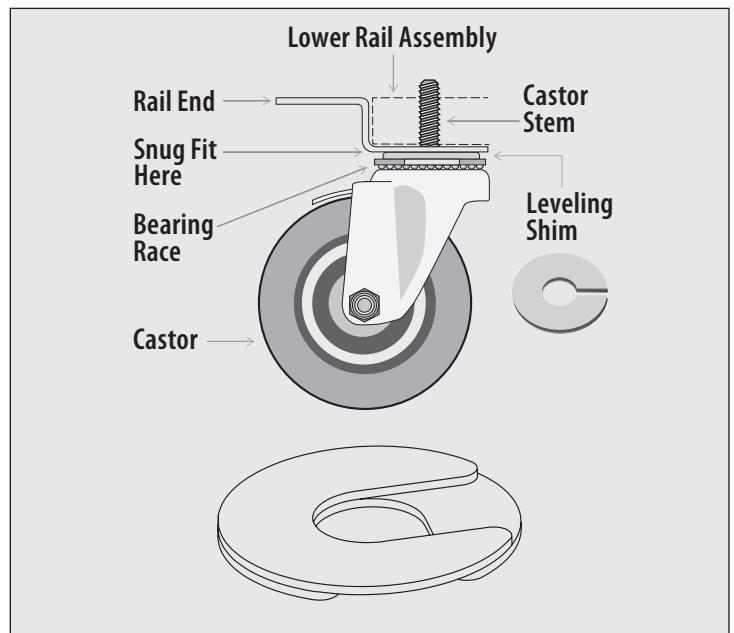

Fig. 4. Stem castor and shims. Install multiple shims with offset slots.

# Installation & Setup (cont.)

## Level the Appliance

⚠ WARNING!	
	<p><b>Tipping hazard! ALWAYS</b> verify center leveling screws, castors, or leveling legs fully contact the floor after leveling the appliance.</p>

Proper leveling of your TRUE appliance is critical to operating success (for non-mobile appliances). Leveling impacts effective condensate removal and door operation.

See "Leveling Screw, Leg or Castor Installation" (pg. 14) for level adjustment and shimming information.

Level the unit front-to-back and side-to-side

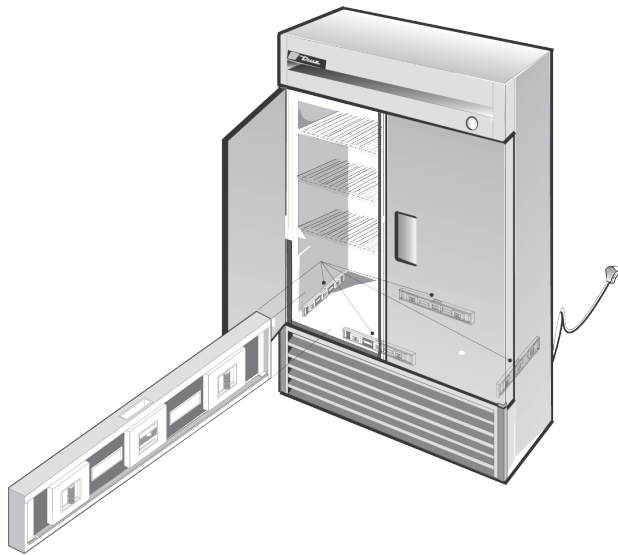



Fig. 1. Measure the level along the perimeter of the interior floor.

## Seal the Appliance to the Floor

ⓘ USER ACTION!	
	<p><b>Asphalt floors are susceptible to chemicals.</b> TRUE recommends installing a layer of tape between the asphalt and the sealant to protect the floor.</p>

If sealing the appliance to the floor, be sure to use NSF-approved sealants. See model-specific installation manuals for more details.

## Shelf Installation

⚠ WARNING!	
	<p><b>All shelving must be properly installed and adhere to load limits. Incorrect installation and improperly loaded or overloaded shelves can result in appliance damage, product damage, or personal injury.</b></p> <p><b>DO NOT use pliers or any crimping tools</b> when installing shelf clips. Altering shelf clips in any way can lead to shelving instability.</p>



### Shelf Adjustment

Shelving is adjustable to meet your application requirements. This appliance meets the IEC Shelf Weight Capacity of 47lb/ft<sup>2</sup> (230kg/m<sup>2</sup>) unless otherwise stated in the model-specific installation manual.

### Installation Tips

- Install **all** the shelf clips before installing any shelves.
- Start at the bottom shelf and work your way up.
- Always lay the back of each shelf down on the rear clips before the front.

## Installation & Setup (cont.)

### Remove the Protective Film

If present, remove the protective door film from the interior door glass. This film protects the anti-fog coating.

1. Locate a loose film edge or corner.
2. Grasp the protective film firmly.
3. Gently pull the film away from the glass. See fig. 1.



**Fig. 1.** Pull the protective film away from the inner glass.

Appliance Operation

# Appliance Operation

**⚠ WARNING – SPOILAGE!**



**The owner is solely responsible** for ensuring safe holding temperature levels for all food items. Failure to do so may result in unsafe food products. Loss or spoilage of products in your appliance is not covered by warranty. In addition to following recommended installation procedures, run the appliance for 24 hours prior to usage to verify operation.



## Startup

**⚠ DANGER!**



**Risk of electric shock or fire!**



Before plugging in the appliance, be sure to inspect the main power cord and plug for damage. Immediately have a qualified technician replace damaged OEM power cords with OEM components.



- The compressor is ready to operate when the appliance is purchased. All you need to do is plug in the appliance.
- Good air flow inside your TRUE appliance is critical. Take care to prevent product from pressing against the sides or back wall and coming within 4" (101.6 mm) of the evaporator housing. Refrigerated air off the evaporator coil must circulate throughout the appliance for even product temperatures.
- Excessive tampering with the control could lead to service difficulties. If replacing the temperature control is ever needed, be sure to order the replacement from your TRUE dealer or recommended service agent.
- All covers and access panels must be in place and properly secured before operating this appliance.

**ⓘ USER ACTION!**





**Before loading product**, run your TRUE appliance empty for 24 hours to verify proper operation. Remember, our factory warranty **DOES NOT** cover product loss!

If the appliance has rested on its back or side, be sure to leave the appliance upright twice the time it was laying down (up to four (4) hours) before restoring power. If this time exceeds four (4) hours, let the appliance stand upright for 24 hours before powering the unit.

## Appliance Operation (cont.)

### Light Switch Location

The light symbol  shows the approximate location of the light switch. 

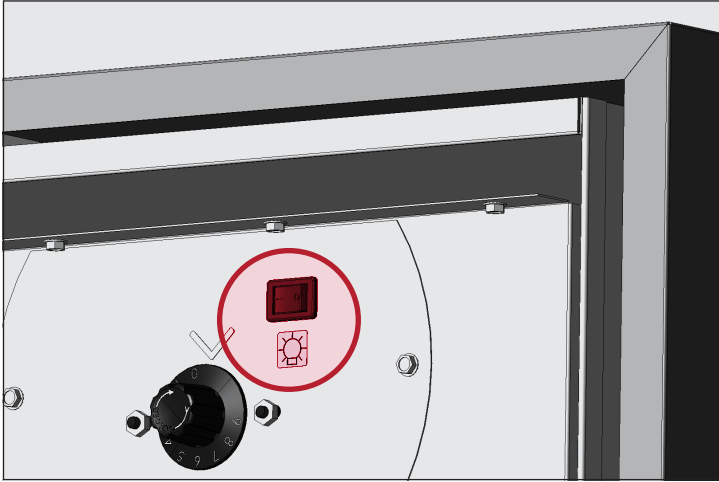

**Fig. 1.** Example of light symbol and light switch location.

### TRULUMINA® Operation



If your unit is equipped with TRULUMINA lighting, see your model-specific manual for operation instructions at [www.truemfg.com/support/manuals/](http://www.truemfg.com/support/manuals/) or follow the QR code on pg. 2.

## Appliance Operation (cont.)

### General Sequence of Operation — Refrigerators & Freezers

#### ! USER ACTION!



For more information regarding an appliance's temperature control adjustment or general sequence of operation, please see our *Commercial Refrigeration General Control Guide* in our resource library at [www.truemfg.com/support/manuals/#panel4](http://www.truemfg.com/support/manuals/#panel4) or scan the QR code.

#### When the appliance is plugged in...

1. The interior lights illuminate on glass door models (if not, see "Light Switch Location" (pg. 18).
2. The electronic temperature control display illuminates (if installed).

#### When the appliance is in refrigeration mode

1. There may be a short delay before the compressor and/or evaporator fan(s) start. This delay may be determined by time or by temperature. This delay may also be the result of an initial defrost event that will be a minimum of six (6) min.
2. The temperature control/thermostat may cycle the compressor and evaporator fan(s) on and off together.  
**EXCEPTION:** models TSID, TDBD, TCGG, and TMW do not have evaporator fan(s).
3. The temperature control cycles the compressor by sensing either an evaporator coil temperature or air temperature, not a product temperature.

##### a. Mechanical Temperature Control or Electronic Temperature Control with a Knob

- i. The temperature control cycles the compressor on and off as determined by the cut-in and cut-out temperatures.
  1. #9 is the coldest position
  2. #1 is the warmest position
  3. #0 or Off is the compressor off position

##### b. Electronic Temperature Control with a Display

- i. The temperature control cycles the compressor on and off as determined by the set point and differential temperatures.
    1. The set point is the adjustable preprogrammed temperature designed to be either the cut-out temperature or it will match the average appliance holding temperature (only when used with a high and low differential).
    2. The differential temperature(s) is the non-adjustable preprogrammed temperature used to determine when the compressor turns on and off (only when the set point is the average holding temperature).
4. An analog thermometer, a digital thermometer, or an electronic control display may reflect the refrigeration cycle swings of up and down temperatures, not a product temperature. **The most accurate method to determine an appliance's operation is to verify the product temperature.**
  5. There may be times during refrigeration mode or defrost mode that the condenser fan motor will reverse to blow dirt off the condenser coil.

## Appliance Operation (cont.)

### General Sequence of Operation — Refrigerators & Freezers (cont.)

#### When the appliance is in defrost mode...

1. Every appliance requires a defrost event to ensure the evaporator coil remains clear of frost and ice buildup.
2. Defrost is initiated either by the temperature control or a defrost timer.  
**EXCEPTION:** Models TDC, TFM, THDC, and TMW require a manual defrost. The frequency of this manual defrost depends on the appliance's usage and ambient conditions.

#### a. Mechanical Temperature Control

- i. The temperature control cycles the compressor on and off as determined by the cut-in and cut-out temperatures.
  1. During this time, only the evaporator fan runs.  
**EXCEPTION:** Models TCGG, TDBD, and TSID do not have an evaporator fan(s).
- ii. A freezer with a mechanical temperature control will defrost by time initiation as determined by a defrost timer.
  1. During this time, only the defrost coil heater and drain tube heater are energized.
  2. Defrost terminates when a specific evaporator coil temperature is reached or by a time duration.
- iii. Models with an analog or digital thermometer may show higher-than-normal temperatures during defrost.

#### b. Electronic Temperature Control

- i. The temperature control is preprogrammed to initiate defrost by a time interval but may also be initiated by temperature demand.
  1. During defrost, a refrigerator turns off the compressor to use the evaporator fans to clear the evaporator coil.
  2. During defrost, a freezer turns off the compressor and evaporator fan to use electric heater to clear the evaporator coil.
- ii. The temperature with a digital display (if installed) shows **dEF** during defrost.
- iii. Models with an analog or digital thermometer may show higher than normal temperatures during defrost.
- iv. After defrost, there is a display delay until temperature is shown.  
**NOTICE >** The display may have a short delay before showing a temperature after defrost has expired and may show **dEF** during a refrigeration cycle.

#### When the appliance sounds an audible and visual alarm...

1. Please reference the appliance's specific temperature control information in Commercial Refrigeration General Control Guide for any alarm codes.

## Appliance Operation (cont.)

### General Sequence of Operation — Heated Appliances

#### ! USER ACTION!



For more information regarding an appliance's temperature control adjustment or general sequence of operation, please see our *Commercial Refrigeration General Control Guide* in our resource library at [www.truemfg.com/support/manuals/#panel4](http://www.truemfg.com/support/manuals/#panel4) or scan the QR code.

When the appliance is plugged in...

1. The interior lights illuminate on glass door models (if not, see "Light Switch Location" (pg. 18).
2. The electronic temperature control display illuminates (if installed).

When the appliance is in heat mode...

1. There may be a short delay before the heater(s) start. This delay may be determined by time or by temperature.
2. The temperature control cycles the heater(s) by sensing air temperature, not a product temperature.
  - a. Mechanical Temperature Control
    - i. The temperature control cycles the heater on and off as determined by the cut-in and cut-out temperatures.
      1. The dial temperature represents the average appliance temperature.
  - b. Electronic Temperature Control with a Display
    - i. The temperature control cycles the heater(s) on and off as determined by the set point and differential temperatures.
      1. The set point is the adjustable preprogrammed temperature designed to be either the cut-out temperature or it will match the average appliance holding temperature (only when used with a high and low differential).
      2. The differential temperature(s) is the non-adjustable preprogrammed temperature used to determine when the compressor turns on and off (only when the set point is the average holding temperature).
3. An analog thermometer, a digital thermometer, or an electronic control display may reflect the heating cycle swings of up and down temperatures, not a product temperature. The most accurate method to determine an appliance's operation is to verify the product temperature.

## Appliance Operation (cont.)

### Temperature Control Adjustment – WITH a Digital Display — Carel PQ



#### Unlock the Control

**NOTE: The control will lock 60 sec after powering up or staying inactive. You cannot manually lock the control.**

1. Press and hold the up arrow . The display shows **Loc.**  
**DO NOT RELEASE THE BUTTON!**



2. While still holding the up arrow, press and hold the down arrow until the display shows **unL.**  
**NOTE: The control will lock 60 sec after powering up or staying inactive.**



#### Change the Set Point

Changing the set point adjusts the appliance operation to keep optimal product temperature.

1. Unlock the control. Once unlocked, the display shows **unL.** before returning to the current appliance temperature.  
**NOTE: The control will lock 60 sec after powering up or staying inactive.**



2. Press and hold set . The display shows **SEt** and then shows the current set point.



3. With the up or down arrow, adjust the set point to the desired setting.



4. Press and release set. The control saves the setting and shows the current appliance temperature.



## Appliance Operation (cont.)

### Temperature Control Adjustment – **WITH** a Digital Display — **Danfoss ERC**





#### Unlock the Control

The display will not lock unless it was originally locked.

1. Press any button to show the current lock status.



2. If the display shows **unL**, the control is unlocked. If the display show **Loc**, press **and hold** both the back button  and the up arrow  until the display shows **unL**.

**NOTICE >** The control will lock after 60 sec of inactivity.



#### Change the Set Point

**NOTICE >** May need to unlock the control

Changing the set point adjusts the appliance temperature to keep optimal product temperature.

1. Press the up  or down  arrow to show the current setting.



2. Press the up or down arrows until the display shows the desired setting.



3. Leave the display inactive until it shows the current appliance temperature.

## Appliance Operation (cont.)

### Temperature Control Adjustment – WITH a Digital Display — Danfoss ETC



#### Change the Set Point

Changing the set point adjusts the appliance temperature to keep optimal product temperature.

1. Press and hold the up arrow  for three (3) seconds to show the current setting.



2. Press the up or down arrows   until the display shows the desired setting.



3. Leave the display inactive until it shows the current appliance temperature.

# Appliance Operation (cont.)

## Temperature Control Adjustment – WITH a Digital Display — LAE BIT25 or BR



### Lock/Unlock the Control

1. Press info [i] to show t1.



2. Press the down arrow [down arrow] to show Loc.



3. Press and hold info to show the current lock status.  
**DO NOT RELEASE THE BUTTON!**



YES = Locked



no = Unlocked

4. Press the arrows to change the lock setting.



5. Release all buttons and wait for the control to display the appliance temperature.

### Change the Set Point

**NOTICE >** May need to unlock the control.

Changing the set point adjusts the appliance temperature to keep optimal product temperature.

1. Press and hold info [i] until the display shows the current set point. **DO NOT RELEASE THE BUTTON!**



2. While holding info, press the up [M] or down [down arrow] arrows to adjust the setting.



3. Release all buttons and wait for the control to display the appliance temperature.

# Appliance Operation (cont.)

## Temperature Control Adjustment – WITH a Digital Display – LAE BD+/BR+ / CD25 / TM

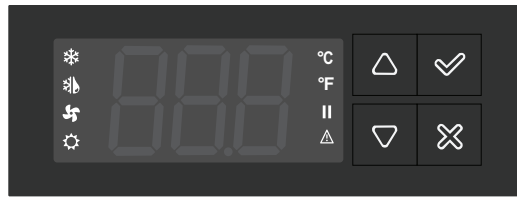

### Lock/Unlock the Control

**NOTICE >** The control will lock 60 sec after powering up or staying inactive.

1. Press and hold confirm  for 5 sec.  
The display will flash **inF** and then show **Loc**.

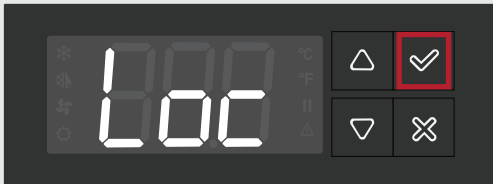

2. Press confirm to show the current lock status

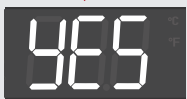

**YES** = Locked

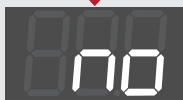

**NO** = Unlocked

3. Press the arrows to change the lock setting.



4. Press confirm. The control saves the setting and proceeds to the next the info menu.

**NOTICE >** The control will lock 60 sec after powering up or staying inactive.



### Change the Set Point

Changing the set point adjusts the appliance temperature to keep optimal product temperature.

1. Unlock the control. Once unlocked, the display shows **Scl**.



2. Press cancel . The display shows the current appliance temperature.

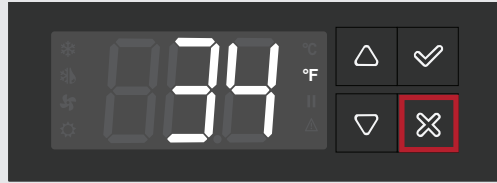

3. Press and hold the up  or down  arrow until the display shows **SP**.

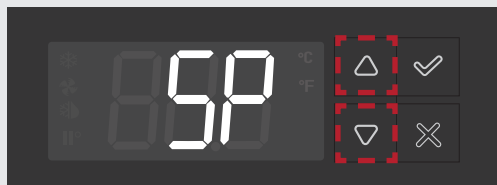

4. With the up or down arrow, adjust the set point to the desired setting.



5. Press confirm . The control saves the setting and the display returns to the current appliance temperature.



## Appliance Operation (cont.)

### Temperature Control Adjustment – **WITHOUT** a Digital Display

See examples below (fig. 1) of temperature control knobs you may find in your appliance.

Turn the temperature control knob clockwise to lower the temperature setting and counterclockwise to raise the temperature setting. One (1) is the warmest setting; Nine (9) is the coldest. See fig. 2.



**Fig. 1.** Temperature control knobs in off position (images not to scale).

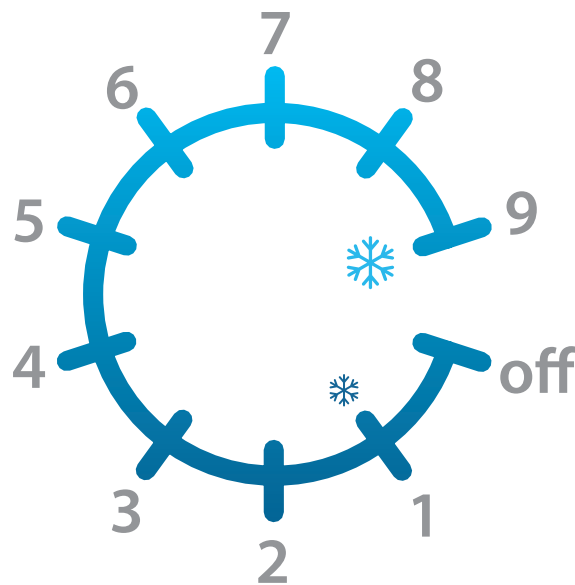





**Fig. 2.** Temperature control knob settings. 1 is the warmest setting; 9 is the coldest.







Maintenance & Servicing

# Maintenance & Servicing

<b>⚠ DANGER!</b>	
	<p><b>Risk of electric shock or burn!</b></p> <ul style="list-style-type: none"> <li>Powering off an electronic control or setting temperature controls to the 0 (off) position <b>DOES NOT remove power from all components.</b> Unplug the appliance or disconnect power before installation or servicing.</li> <li><b>DO NOT</b> clean appliance with a pressure washer or hose.</li> </ul>
	<p><b>Flammable refrigerant/insulation used!</b> Have a licensed service provider service your appliance to minimize the risk of possible ignition due to incorrect parts or improper service and to ensure the operator's health and safety.</p>

<b>⚠ WARNING!</b>	
	<p><b>Sharp Edges!</b></p> <ul style="list-style-type: none"> <li>Take care when moving, installing, cleaning, servicing, and maintaining the appliance to avoid cuts. Be sure to take care when reaching under the appliance or handling metal components.</li> <li>Stay clear of pinch point areas, such as the space between appliance doors and surrounding cabinetry. Take care closing doors with children nearby.</li> </ul>
	<p><b>Crush or cut hazard!</b> Keep clear when uncrating, installing, moving, or servicing the appliance.</p>
	<p><b>Slippery Surfaces!</b> Moisture from improper drainage can create slippery surfaces near the appliance. It is your duty to immediately warn your customers of, and dry, the slippery surface. All wet floor areas must be marked with a wet floor sign.</p>

<b>⚠ WARNING!</b>	
	<ul style="list-style-type: none"> <li><b>Only qualified technicians</b> should install and service the appliance. For assistance locating a refrigeration service technician in your area for installation, servicing or maintenance, please visit our Service Company Locator (see links and QR codes on pg. 2).</li> <li><b>Turn off and lockout all utilities</b> (gas, electric, water) according to approved practices during maintenance or servicing.</li> </ul>
  	<p><b>The appliance owner is responsible</b> for performing a Personal Protective Equipment (PPE) Hazard Assessment and ensuring adequate protection during maintenance and cleaning procedures.</p> <p><b>Use appropriate tools,</b> safety equipment, and PPE during installation and servicing.</p>

Maintenance & Servicing (cont.)

**! USER ACTION!**

- See detailed maintenance and servicing information in our model-specific installation manuals; find your model-specific installation manual at [www.truemfg.com/support/manuals](http://www.truemfg.com/support/manuals), the QR code on pg. 2, or contact TRUE's Technical Support Department.
- Any appliance adjustments are to be made **AFTER** the appliance has been verified level and properly supported.

**! NOTICE!**

The appliance owner is responsible for maintaining the appliance as described in the installation manual. Routine care and maintenance procedures are not covered by TRUE's warranty.



Fig. 1. Example of OEM parts.

Component Replacement





**! USER ACTION!**

- Replace components with original equipment manufacturer (OEM) components such as those shown in fig. 1. OEM parts minimize the risk of possible ignition due to incorrect parts. True is not responsible for defects or damage caused by parts not approved by TRUE. Warranty will be voided for any damage caused by a non-OEM part.
- Have a licensed service provider service your appliance to minimize the risk of possible ignition due to incorrect parts or improper service and to ensure the operator's health and safety.

# Maintenance & Servicing (cont.)

## Condenser Coil Cleaning

<b>⚠ DANGER!</b>	
	<p><b>Risk of electric shock or burn!</b></p> <ul style="list-style-type: none"> <li>• Unplug the appliance or turn off the power supply before installation or servicing.</li> <li>• <b>DO NOT</b> clean appliance with a pressure washer or hose.</li> </ul>

<b>⚠ WARNING!</b>	
  	<p><b>The appliance owner is responsible</b> for performing a Personal Protective Equipment (PPE) Hazard Assessment and to ensure adequate protection during maintenance and cleaning procedures.</p> <p><b>Use appropriate tools</b>, safety equipment, and PPE during installation and servicing.</p>
	<p><b>Sharp edges!</b> Coil fins are sharp and metal components can have sharp edges. Take care when moving, installing, cleaning, servicing, and maintaining the appliance to avoid cuts.</p>
	<p><b>Risk of eye injury!</b> Airborne dust and debris can cause eye injury. Eye protection recommended.</p>

<b>! NOTICE!</b>	
	<p>Condenser coils may accumulate dirt over time. Dirty condenser coils can cause product failure and it is recommended that they be checked every 30 days.</p>

On most units, the condenser is accessible by removing the appliance's louver grill or cover. See Model-Specific Installation Manuals for specific instructions.



Condenser coils accumulate dirt and require checking every 30 days or as needed.





You may remove dust or debris from the condenser coil via one of the following methods monthly or as needed:

- Brush debris away with a stiff-bristled brush. Never brush across coil fins.
- Vacuum the coil fins with a shop vac.
- Gently blow CO<sub>2</sub>, nitrogen, or pressurized air through the coil fins.

**DO NOT** place any filter material in front of the condensing coil. If you cannot adequately remove the dust and debris, please contact a qualified technician.

## General Surface Care & Cleaning

<b>⚠ DANGER!</b>	
 	<p><b>Risk of electrical shock or fire!</b></p> <p><b>DO NOT</b> clean appliance with a pressure washer or hose.</p>

<b>⚠ WARNING!</b>	
	<p><b>Slippery Surfaces!</b> Moisture from improper drainage can create slippery surfaces near the appliance. It is your duty to immediately warn your customers of, and dry, the slippery surface. All wet floor areas must be marked with a wet floor sign.</p>
  	<p><b>The appliance owner is responsible</b> for performing a Personal Protective Equipment (PPE) Hazard Assessment and to ensure adequate protection during maintenance and cleaning procedures.</p> <p><b>Use appropriate tools</b>, safety equipment, and PPE during installation and servicing.</p>

### Gaskets

- Clean gaskets with warm soapy water.
- **DO NOT** use sharp tools or knives to scrape a gasket.
- Avoid full-strength cleaning products.

### Glass

- Clean glass with a mild glass cleaner. **DO NOT** use citrus-based cleaners.

### Interior

- Clean interior surfaces with a mild solution of baking soda and water to help reduce odor; **DO NOT** use harsh or abrasive cleaners.
- For plastic or powder-coated parts, use warm soapy water to clean **DO NOT** use stainless steel cleaners or similar solvents.

### Exterior

- For plastic or powder-coated parts, use warm soapy water to clean **DO NOT** use stainless steel cleaners or similar solvents.
- **DO NOT** clean stainless steel with steel wool or abrasive products. **DO NOT** use detergents or degreasers with chlorides or phosphates. See model-specific manual for more information.

## Maintenance & Servicing (cont.)

### Recommended Maintenance

See recommended maintenance tasks and frequencies below. Some tasks may be required more frequently based on your installation.

Maintenance Tasks	Monthly	Quarterly	Annually
Verify the appliance maintains product temperature.	X	X	X
Inspect power cord for damage; if damaged, replace immediately.	X	X	X
Verify the power cord is fully plugged into the wall receptacle			X
Inspect the overall condition of the appliance and its components (such as castors, doors, and hinges).	X	X	X
Verify operation of all moving parts (such as fan motors, doors and door cords).			X
Check physical condition of all gaskets; verify gaskets seal correctly.		X	X
Inspect any lamps, lamp holder connections, LED modules, and LED module connections.	X	X	X
Check all condenser coils (fronts and backs) for dust and debris; if present, clear the debris.	X	X	X
Check physical condition of all condenser coils and evaporator coils; straighten coil fins as needed.		X	X
Check all evaporator coils for dust and debris; if present, clear the debris.		X	X
Verify the drain line is clear of debris.		X	X





Warranty Information (USA, Canada & Puerto Rico Only)

# Warranty Information

To view and download the  
Warranty Information for USA, Canada & Puerto Rico  
please scan the QR code below.



*TRUE*®

[truemfg.com](http://truemfg.com)