



UNDERCOUNTER & WORKTOP REFRIGERATION





UNDERCOUNTER REFRIGERATION

The undercounter series offers exceptional refrigeration that slides easily under existing countertops for space efficiency, or provides a functional work surface for easy food preparation and reliable cold storage.

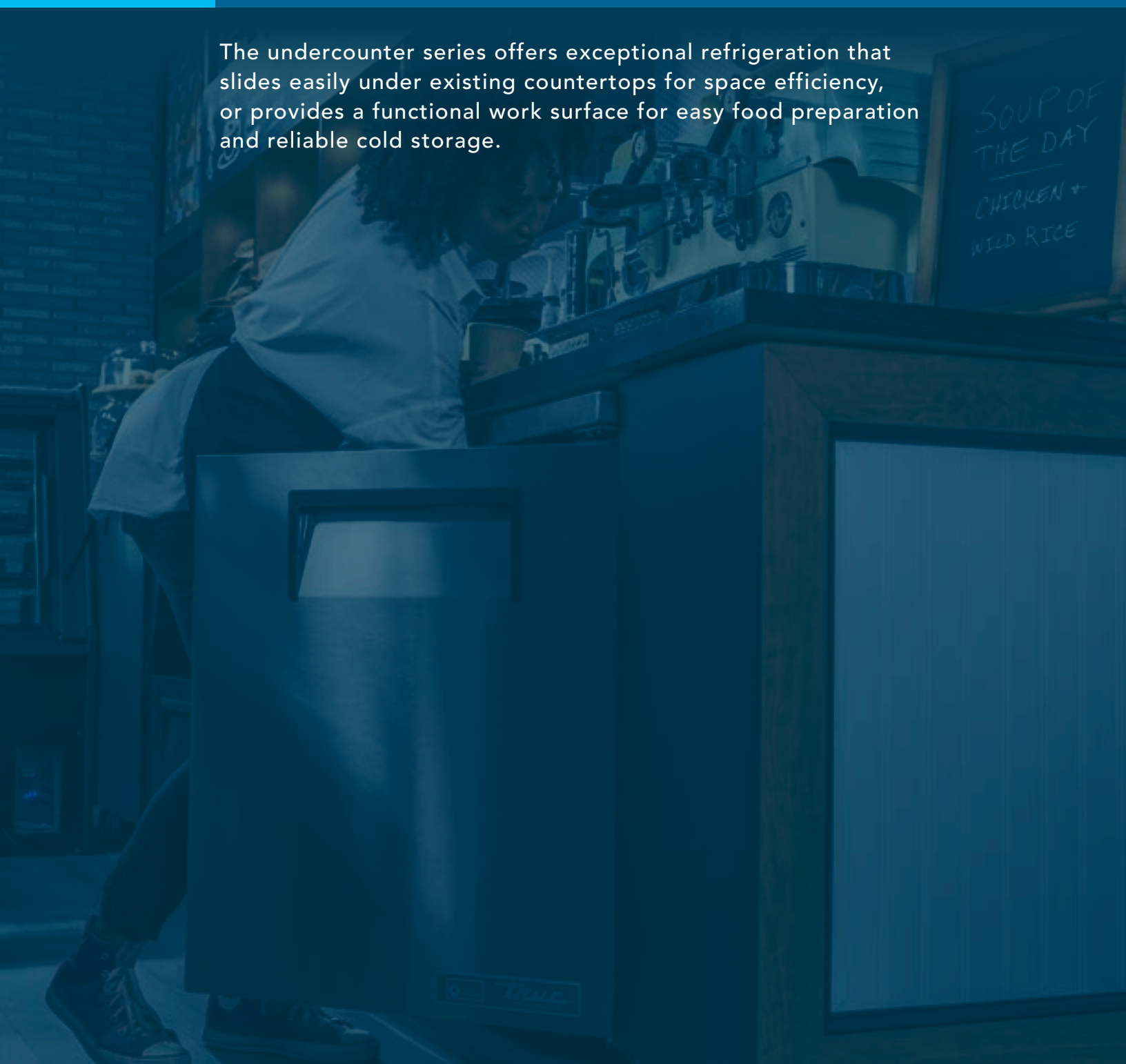



UNDERCOUNTER REFRIGERATORS

Solid & Glass Doors, Solid Drawers



TUC-48-HC



TUC-27-HC-FGD01



TUC-27-HC



TUC-48D-4-HC



TUC-72-HC

Features/Benefits

- Refrigerators maintain cold 33°F to 38°F (0.5°C to 3.3°C) product temperatures.
- All stainless steel front, top and sides.
- Corrosion resistant GalFan coated steel back.
- Interior - attractive, clear aluminum sides and top, coved corners and stainless steel floor.
- Recessed handles
- Adjustable, heavy-duty, PVC-coated wire shelves (not available in drawered models).
- Work surface 36" (915mm) high.
- Low profile models (31-7/8" (810mm) work surface height) upcharge applies or ADA compliant with 34" (864mm) work surface height available; no charge. (models -27, -36, -48, -60, -72).
- All production of True models comply with NSF/ANSI standard 7.
- Self-contained system.

Glass Door Model have...

- Energy efficient, "Low-E", thermal insulated glass doors on refrigerator models (triple pane thermal insulated glass on freezer models).
- Extruded, aluminum door frames.
- Each door fitted with 12" (305 mm) long extruded aluminum handle.
- LED interior lighting provides more even lighting throughout the cabinet. Safety shielded.

Drawer Models have...

- Accommodates one 12" L x 20" W x 6" D (305mm x 508mm x 153mm) full size pan or two ½ pans or three ⅓ pans per drawer. (48" (1,220mm) models accommodate one 12" L x 18" W x 6" D (305mm x 408mm x 153mm) food storage box or one ⅓ size and one ½ size pan per drawer; not included).
- Door/drawer combination models require customer to designate door/drawer orientation.



TUC® UNDERCOUNTER REFRIGERATORS

Model	Door/Drawers	# of Shelves	HP	Amps	Crated Weight lb. (kg.)	Cabinet Dimensions W D† H* (in)	Cabinet Dimensions W D† H* (mm)
SOLID DOORS							
TUC-24-HC	1/0	2	1/6	2.0	155 (71)	24 ³ / ₈ x 24 ⁷ / ₈ x 31 ⁵ / ₈	613 x 630 x 802
TUC-27-HC	1/0	2	1/6	2.0	195 (89)	27 ⁵ / ₈ x 30 ¹ / ₈ x 29 ³ / ₄	702 x 766 x 756
TUC-36-HC	2/0	4	1/6	2.0	235 (107)	36 ³ / ₈ x 30 ¹ / ₈ x 29 ³ / ₄	924 x 766 x 756
TUC-48-HC	2/0	4	1/5	2.0	260 (118)	48 ³ / ₈ x 30 ¹ / ₈ x 29 ³ / ₄	1229 x 766 x 756
TUC-60-HC	2/0	4	1/4	4.0	320 (146)	60 ³ / ₈ x 30 ¹ / ₈ x 29 ³ / ₄	1534 x 766 x 756
TUC-72-HC	3/0	6	1/4	4.0	380 (173)	72 ³ / ₈ x 30 ¹ / ₈ x 29 ³ / ₄	1839 x 766 x 756
GLASS DOORS							
TUC-24G-HC~FGD01	1/0	2	1/6	2.0	165 (75)	24 x 24 ³ / ₄ x 31 ⁵ / ₈	610 x 629 x 804
TUC-27G-HC~FGD01	1/0	2	1/6	2.0	205 (93)	27 ⁵ / ₈ x 30 ¹ / ₈ x 29 ³ / ₄	702 x 766 x 756
TUC-48G-HC~FGD01	2/0	4	1/5	3.0	285 (130)	48 ³ / ₈ x 30 ¹ / ₈ x 29 ³ / ₄	1229 x 766 x 756
TUC-60G-HC~FGD01	2/0	4	1/4	4.0	350 (159)	60 ³ / ₈ x 30 ¹ / ₈ x 29 ³ / ₄	1534 x 766 x 756
WITH DRAWERS OR DOOR/DRAWER COMBO							
TUC-27D-2-HC	0/2	N/A	1/6	2.0	225 (103)	27 ⁵ / ₈ x 30 ¹ / ₈ x 29 ³ / ₄	702 x 766 x 756
TUC-48D-2-HC	1/2	2	1/5	3.0	310 (141)	48 ³ / ₈ x 30 ¹ / ₈ x 29 ³ / ₄	1229 x 766 x 756
TUC-48D-4-HC	0/4	N/A	1/5	3.0	330 (150)	48 ³ / ₈ x 30 ¹ / ₈ x 29 ³ / ₄	1229 x 766 x 756
TUC-60D-2-HC	1/2	2	1/4	4.0	445 (202)	60 ³ / ₈ x 30 ¹ / ₈ x 29 ³ / ₄	1534 x 766 x 756
TUC-60D-4-HC	0/4	N/A	1/4	4.0	400 (182)	60 ³ / ₈ x 30 ¹ / ₈ x 29 ³ / ₄	1534 x 766 x 756

† Depth does not include 1" (26mm) for rear bumpers and 1/2" (13mm) for glass door handles.

* Height does not include 6 1/4" (159mm) for castors or 6" (153mm) for optional legs. (Excludes TUC-24-HC)

note: Door/drawer combination cabinets require customer to designate door/drawer orientation.

TFT™ UNDERCOUNTER FLAT TOP REFRIGERATORS

Model	Door/Drawers	# of Shelves	HP	Amps	Crated Weight lb. (kg.)	Cabinet Dimensions W D† H* (in)	Cabinet Dimensions W D† H* (mm)
SOLID DOORS							
TFT-32-HC	1/0	2	1/5	1.6	260 (118)	32 ¹ / ₂ x 31 ¹ / ₂ x 35 ⁷ / ₈	816 x 800 x 911
WITH DRAWERS							
TFT-32D-2-HC	0/2	N/A	1/5	1.6	315 (143)	32 ¹ / ₂ x 31 ¹ / ₂ x 35 ⁷ / ₈	816 x 800 x 911

Environmentally friendly R290 hydrocarbon refrigeration system for the best in food preservation.



DEEP UNDERCOUNTER REFRIGERATORS

Solid Doors & Drawers

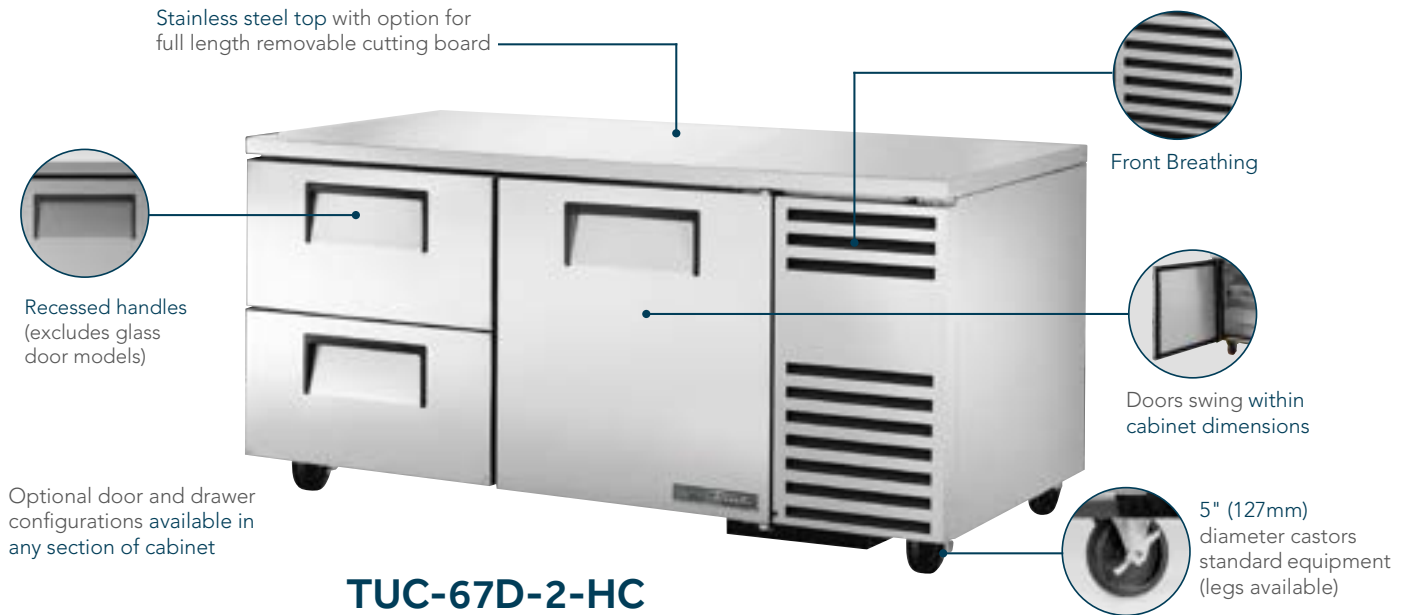

TUC-44-HC



TUC-60-32D-2-HC



TUC-67-HC



TUC-93D-4-HC

Features/Benefits

- Refrigerators maintain cold 33°F to 38°F (0.5°C to 3.3°C) product temperatures.
- Features the combined advantage of convenient undercounter placement with deeper refrigerated storage.
- Easily slides under counters, maximizes space for refrigerated food storage in fast food line-up.
- Balanced circular airflow for uniform product cooling.
- All stainless steel front, top and sides.
- Corrosion resistant GalFan coated steel back.
- Interior - attractive, clear aluminum sides and top, coved corners and stainless steel floor.
- Work surface 36" (915mm) high.
- Adjustable, heavy-duty, PVC-coated wire shelves (not available in drawered models).
- Front breathing.
- Door models accommodate half bun tray rack; applies to only one door of TUC-60-32 (18" x 26" sheet pan (458mm x 661mm)) - not included.
- All production of True models comply with NSF/ANSI standard 7.
- Additional castor and leg options available.
- Self-contained system.

Drawer Models have...

- Accommodates one 12" L x 20" W x 8" D (305mm x 508mm x 204mm) full size pan or four 1/2 pans or six 1/3 pans per drawer. Pans not included.
- Door/drawer combination models require customer to designate door/drawer orientation.



TUC® DEEP UNDERCOUNTER REFRIGERATORS

Model	Door/Drawers	# of Shelves	HP	Amps	Crated Weight lb. (kg.)	Cabinet Dimensions W D† H* (in)	Cabinet Dimensions W D† H* (mm)
SOLID DOORS							
TUC-44-HC	1/0	2	1/10	1.7	285 (123)	44 ⁷ / ₈ x 32 ¹ / ₄ x 29 ³ / ₄	1138 x 818 x 756
TUC-60-32-HC	2/0	4	1/10	1.7	415 (189)	60 ¹ / ₄ x 32 ¹ / ₄ x 29 ³ / ₄	1531 x 818 x 756
TUC-67-HC	2/0	4	1/10	1.7	410 (186)	67 ¹ / ₄ x 32 ¹ / ₄ x 29 ³ / ₄	1709 x 818 x 756
TUC-93-HC	3/0	6	1/5	2.2	515 (234)	93 ¹ / ₄ x 32 ¹ / ₄ x 29 ³ / ₄	2369 x 818 x 756
WITH DRAWERS OR DOOR/DRAWER COMBO							
TUC-44D-2-HC	0/2	N/A	1/10	1.7	285 (130)	44 ⁷ / ₈ x 32 ¹ / ₄ x 29 ³ / ₄	1138 x 818 x 756
TUC-60-32D-2-HC	1/2	2	1/10	1.7	345 (156)	60 ¹ / ₄ x 32 ¹ / ₄ x 29 ³ / ₄	1531 x 818 x 756
TUC-67D-2-HC	1/2	2	1/10	1.7	485 (220)	67 ¹ / ₄ x 32 ¹ / ₄ x 29 ³ / ₄	1708 x 818 x 756
TUC-67D-4-HC	0/4	N/A	1/10	1.7	390 (177)	67 ¹ / ₄ x 32 ¹ / ₄ x 29 ³ / ₄	1708 x 818 x 756
TUC-93D-2-HC	2/2	4	1/5	2.2	640 (291)	93 ¹ / ₄ x 32 ¹ / ₄ x 29 ³ / ₄	2369 x 818 x 756
TUC-93D-4-HC	1/4	2	1/5	2.2	640 (291)	93 ¹ / ₄ x 32 ¹ / ₄ x 29 ³ / ₄	2369 x 818 x 756
TUC-93D-6-HC	0/6	N/A	1/5	2.2	550 (250)	93 ¹ / ₄ x 32 ¹ / ₄ x 29 ³ / ₄	2369 x 818 x 756

† Depth does not include 1" (26mm) for rear bumpers or 1/4" (7mm) for front bumper.

* Height does not include 6 1/4" (159mm) for castors or 6" (153mm) for optional legs.

note: Door/drawer combination cabinets require customer to designate door/drawer orientation.

Environmentally friendly R290 hydrocarbon refrigeration system for the best in food preservation.



Undercounter | TUC®~SPEC3

UNDERCOUNTER REFRIGERATORS ~SPEC3 SERIES

Solid & Glass Doors, Solid Drawers

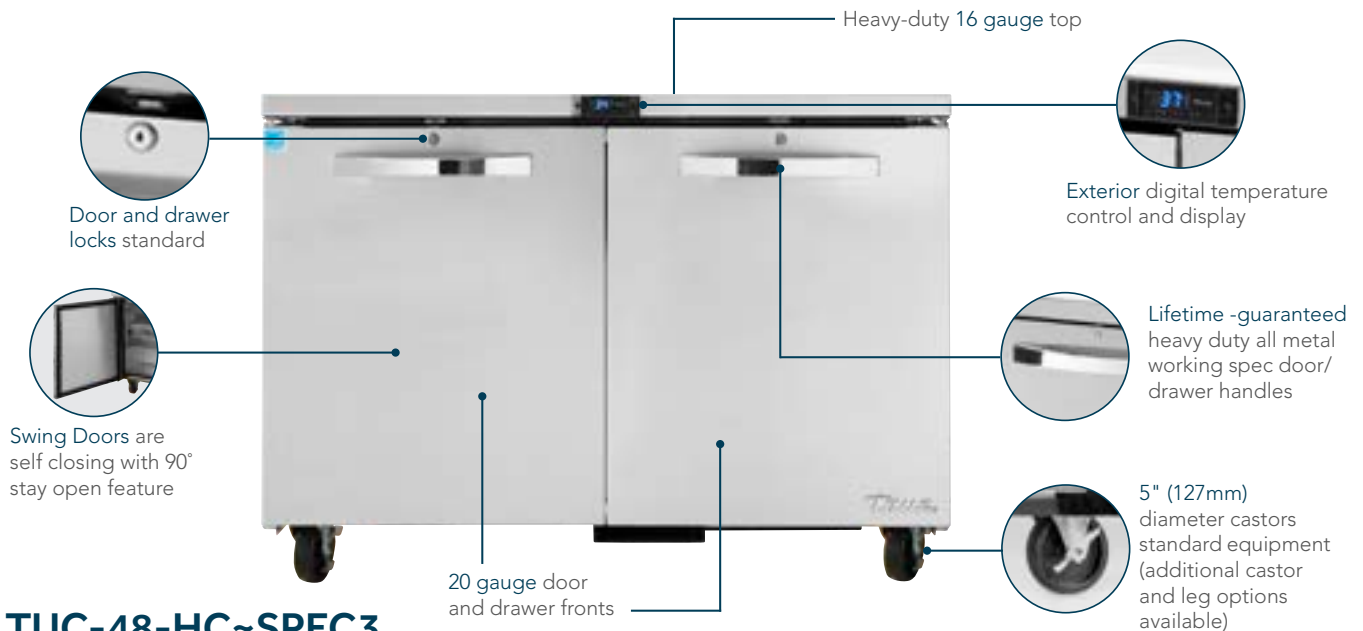

TUC-48-HC~SPEC3



TUC-27-HC~SPEC3



TUC-48G-HC~SPEC3



TUC-60-HC~SPEC3



TUC-60D-4-HC~SPEC3

Features/Benefits

- Refrigerators maintain cold 33°F to 38°F (0.5°C to 3.3°C) product temperatures.
- All stainless steel front, countertop, sides and back.
- Interior features stainless steel liner and stainless steel floor with coved corners.
- Adjustable, heavy-duty, PVC-coated wire shelves (not available in drawer models).
- Doors swing within cabinet dimensions.
- Work surface 36" (915mm) high.
- Low profile models (31-7/8" (810mm) work surface height) upcharge applies or ADA compliant with 34" (864mm) work surface height available; no charge. (models -27, -36, -48, -60, -72).
- All production of True models comply with NSF/ANSI standard 7.
- Self-contained system.

Glass Door Model have...

- Energy efficient, "Low-E", double paned thermal insulated glass doors on refrigerator models (triple paned thermal insulated glass doors on freezer models).
- Extruded, aluminum door frames.
- LED interior lighting provides more even lighting throughout the cabinet. Safety shielded.

Drawer Models have...

- Standard depth models accommodate one 12" L x 20" W x 8" D (305mm x 508mm x 204mm) full size pan or four 1/2 pans or six 1/3 pans per drawer. Pans not included.
- Door/drawer combination models require customer to designate door/drawer orientation.



TUC® UNDERCOUNTER REFRIGERATORS ~SPEC3 SERIES

Model	Door/Drawers	# of Shelves	HP	Amps	Crated Weight lb. (kg.)	Cabinet Dimensions W D† H* (in)	Cabinet Dimensions W D† H* (mm)
SOLID DOORS							
TUC-24-HC~SPEC3	1/0	2	1/6	2.0	155 (71)	24 x 24¾ x 31½	610 x 629 x 804
TUC-27-HC~SPEC3	1/0	2	1/6	2.0	185 (84)	27½ x 29½ x 29¾	702 x 740 x 756
TUC-36-HC~SPEC3	2/0	4	1/6	2.0	240 (109)	36½ x 29½ x 29¾	922 x 740 x 756
TUC-48-HC~SPEC3	2/0	4	1/5	2.0	305 (139)	48½ x 29½ x 29¾	1229 x 740 x 756
TUC-60-HC~SPEC3	2/0	4	1/4	4.0	355 (162)	60½ x 29½ x 29¾	1534 x 740 x 756
TUC-72-HC~SPEC3	3/0	6	1/4	4.0	380 (173)	72½ x 29½ x 29¾	1839 x 740 x 756
GLASS DOORS							
TUC-27G-HC~SPEC3	1/0	2	1/6	2.0	205 (93)	27½ x 29½ x 29¾	702 x 740 x 756
TUC-48G-HC~SPEC3	2/0	4	1/5	3.0	285 (130)	48½ x 29½ x 29¾	1227 x 740 x 756
TUC-60G-HC~SPEC3	2/0	4	1/4	4.0	350 (159)	60½ x 29½ x 29¾	1534 x 740 x 756
WITH DRAWERS OR DOOR/DRAWER COMBO							
TUC-27D-2-HC~SPEC3	0/2	N/A	1/6	2.0	225 (103)	27½ x 29½ x 29¾	702 x 740 x 756
TUC-48D-2-HC~SPEC3	1/2	2	1/5	3.0	310 (141)	48½ x 29½ x 29¾	1229 x 740 x 756
TUC-48D-4-HC~SPEC3	0/4	N/A	1/5	3.0	330 (150)	48½ x 29½ x 29¾	1229 x 740 x 756
TUC-60D-2-HC~SPEC3	1/2	2	1/4	4.0	445(202)	60½ x 29½ x 29¾	1534 x 740 x 756
TUC-60D-4-HC~SPEC3	0/4	N/A	1/4	4.0	400 (182)	60½ x 29½ x 29¾	1534 x 740 x 756

† Depth does not include 1½" (39mm) for door handles.

† Depth does not include 1" (26mm) for rear bumpers.

* Height does not include 6¼" (159mm) for castors or 6" (153mm) for optional legs. (Excludes TUC-24-HC~SPEC3)

note: Door/drawer combination cabinets require customer to designate door/drawer orientation.

Environmentally friendly R290 hydrocarbon refrigeration system for the best in food preservation.



Undercounter | TUC[®] Deep~SPEC3

UNDERCOUNTER DEEP REFRIGERATORS ~SPEC3

Solid Doors & Drawers



TUC-67D-2-HC~SPEC3



TUC-44D-2-HC~SPEC3



TUC-60-32D-2-HC~SPEC3



TUC-67-HC~SPEC3



TUC-93D-2-HC~SPEC3

Features/Benefits

- Refrigerators maintain cold 33°F to 38°F (0.5°C to 3.3°C) product temperatures..
- Features the combined advantage of convenient undercounter placement with deeper refrigerated storage.
- All stainless steel front, countertop, sides and back.
- Interior features stainless steel liner and stainless steel floor with coved corners.
- Adjustable, heavy-duty, PVC-coated wire shelves (not available in drawered models).
- Doors swing within cabinet dimensions.
- Work surface 36" (915mm) high.

- Accommodates half bun tray rack; applies to only one door of TUC-60-32 (18" x 26" sheet pan (458mm x 661mm)) - not included.
- ADA compliant with 34" (864mm) work surface height available; no charge.
- All production of True models comply with NSF/ANSI standard 7.
- Self-contained system.

Drawer Models have...

- Accommodates one 12" L x 20" W x 8" D (305mm x 508mm x 204mm) full size pan or four 1/2 pans or six 1/3 pans per drawer. Pans not included.
- Door/drawer combination models require customer to designate door/drawer orientation.



TUC® DEEP UNDERCOUNTER REFRIGERATORS ~SPEC3 SERIES

Model	Door/Drawers	# of Shelves	HP	Amps	Crated Weight lb. (kg.)	Cabinet Dimensions W D† H* (in)	Cabinet Dimensions W D† H* (mm)
SOLID DOORS							
TUC-44-HC~SPEC3	1/0	2	1/10	1.7	285 (130)	44 7/8 x 32 1/4 x 29 3/4	1138 x 818 x 756
TUC-60-32-HC~SPEC3	2/0	4	1/10	1.7	415 (189)	60 1/4 x 32 1/4 x 29 3/4	1531 x 818 x 756
TUC-67-HC~SPEC3	2/0	4	1/10	1.7	410 (186)	67 1/4 x 32 1/4 x 29 3/4	1709 x 818 x 756
TUC-93-HC~SPEC3	3/0	6	1/5	2.2	515 (234)	93 1/4 x 32 1/4 x 29 3/4	2369 x 818 x 756
WITH DRAWERS OR DOOR/DRAWER COMBO							
TUC-44D-2-HC~SPEC3	0/2	N/A	1/10	1.7	270 (123)	44 7/8 x 32 1/4 x 29 3/4	1138 x 818 x 756
TUC-60-32D-2-HC~SPEC3	1/2	2	1/10	1.7	345 (156)	60 1/4 x 32 1/4 x 29 3/4	1531 x 818 x 756
TUC-67D-2-HC~SPEC3	1/2	2	1/10	1.7	430 (193)	67 1/4 x 32 1/4 x 29 3/4	1709 x 818 x 756
TUC-67D-4-HC~SPEC3	0/4	N/A	1/10	1.7	390 (177)	67 1/4 x 32 1/4 x 29 3/4	1709 x 818 x 756
TUC-93D-2-HC~SPEC3	2/2	4	1/5	2.2	640 (291)	93 1/4 x 32 1/4 x 29 3/4	2369 x 818 x 756
TUC-93D-4-HC~SPEC3	1/4	2	1/5	2.2	640 (291)	93 1/4 x 32 1/4 x 29 3/4	2369 x 818 x 756
TUC-93D-6-HC~SPEC3	0/6	N/A	1/5	2.2	685 (311)	93 1/4 x 32 1/4 x 29 3/4	2369 x 818 x 756

† Depth does not include 1" (26mm) for rear bumpers or 1/4"(7mm) for front bumper.

* Height does not include 6 1/4" (159mm) for castors or 6"(153mm) for optional legs.

note: Door/drawer combination cabinets require customer to designate door/drawer orientation.

Environmentally friendly R290 hydrocarbon refrigeration system for the best in food preservation.



UNDERCOUNTER FREEZERS

Solid Doors & Drawers



TUC-24F-HC



TUC-27F-D-2-HC



TUC-48F-D-4-HC



TUC-60F-HC

Features/Benefits

- Freezers maintain -10°F (-23.3°C) product temperatures.
- Automatic defrost system on freezer models time-initiated, time-terminated.
- All stainless steel front, top and sides.
- Corrosion resistant GalFan coated steel back.
- Interior - attractive, NSF/ANSI standard 7 approved, clear aluminum sides and top, coved corners and stainless steel floor.
- Recessed handles
- Adjustable, heavy-duty, PVC-coated wire shelves (not available in drawered models).
- Work surface 36" (915mm) high.
- Low profile models (31-7/8" (810mm) work surface height) upcharge applies or ADA compliant with 34" (864mm) work surface height available; no charge. (models -27, -36, -48, -60, -72).
- Self-contained system.

FLX models...

- Easily converts from freezer to refrigerator with the flip of a switch.

Glass Door Model have...

- Energy efficient, "Low-E", double paned thermal insulated glass doors on refrigerator models (triple paned thermal insulated glass on freezer models).
- Extruded, aluminum door frames.
- Each door fitted with 12" (305 mm) long extruded aluminum handle.
- LED interior lighting provides more even lighting throughout the cabinet. Safety shielded.

Drawer Models have...

- Accommodates one 12" L x 20" W x 6" D (305mm x 508mm x 153mm) full size pan or two 1/2 pans or three 1/3 pans per drawer. (48" (1,220mm) models accommodate one 12" L x 18" W x 6" D (305mm x 408mm x 153mm) food storage box or one 1/3 size and one 1/2 size pan per drawer; not included).
- Door/drawer combination models require customer to designate door/drawer orientation.



TUC® UNDERCOUNTER FREEZERS

Model	Door/Drawers	# of Shelves	HP	Amps	Crated Weight lb. (kg.)	Cabinet Dimensions W D† H* (in)	Cabinet Dimensions W D† H* (mm)
SOLID DOORS							
TUC-24F-HC	1/0	2	¼	2.3	165 (75)	24 x 24¾ x 31½	610 x 629 x 804
TUC-27F-HC	1/0	2	¼	2.3	190 (87)	27½ x 30½ x 29¾	702 x 766 x 756
TUC-48F-HC	2/0	4	⅓	3.2	275 (125)	48¾ x 30½ x 29¾	1229 x 766 x 756
TUC-60F-HC	2/0	4	½	4.8	335 (152)	60¾ x 30½ x 29¾	1534 x 766 x 756
WITH DRAWERS							
TUC-27F-D-2-HC	0/2	N/A	¼	2.3	220 (100)	27½ x 30½ x 29¾	702 x 766 x 756
TUC-48F-D-4-HC	0/4	N/A	⅓	3.2	325 (148)	48¾ x 30½ x 29¾	1229 x 766 x 756

† Depth does not include 1" (26mm) for rear bumpers.

* Height does not include 6¼"(159mm) for castors or 6"(153mm) for optional legs. (Excludes TUC-24-HC)

note: Door/drawer combination cabinets require customer to designate door/drawer orientation.

FLX UNDERCOUNTER CONVERTIBLE REFRIGERATOR/FREEZER

Model	Doors/Drawers	# of Shelves	HP	Amps	Crated Weight lb. (kg.)	Cabinet Dimensions W D† H* (in)	Cabinet Dimensions W D† H* (mm)
SOLID DOORS							
TUC-27F-FLX-HC	1/0	2	¼	2.3	190 (87)	27½ x 30½ x 29¾	702 x 766 x 756

† Depth does not include 1" (26mm) for rear bumpers.

* Height does not include 6¼" (159mm) for castors or 6" (153mm) for optional legs.



Environmentally friendly R290 hydrocarbon refrigeration system for the best in food preservation.



All dimensions are rounded up to the nearest 1/8" (whole millimeter) | Specifications subject to change without notice.

DEEP UNDERCOUNTER FREEZERS

Solid Doors



TUC-44F-HC



TUC-67F-HC

Features/Benefits

- Freezers maintain -10°F (-23.3°C) product temperatures.
 - Features the combined advantage of convenient undercounter placement with deeper refrigerated storage.
 - Easily slides under counters, maximizes space for refrigerated food storage in fast food line-up.
 - Automatic defrost system on freezer models time-initiated, time-terminated.
 - 360° circular airflow for uniform product cooling.
 - All stainless steel front, top and sides.
 - Corrosion resistant GalFan coated steel back.
 - Interior - attractive, clear aluminum sides and top, coved corners and stainless steel floor.
 - Work surface 36" (915mm) high.
 - Adjustable, heavy-duty, PVC-coated wire shelves (not available in drawer models).
 - Front breathing.
 - Door models accommodate half bun tray rack; applies to only one door of TUC-60-32 (18" x 26" (458mm x 661mm) sheet pan) - not included.
 - All production of True models comply with NSF/ANSI standard 7.
 - Available with optional 3" (77mm) diameter castors.
 - Self-contained system.
- Drawer Models have...**
- Accommodates one 12" L x 20" W x 8" D (305mm x 508mm x 204mm) full size pan or four 1/2 pans or six 1/3 pans per drawer. Pans not included.
 - Door/drawer combination models require customer to designate door/drawer orientation.



TUC® DEEP UNDERCOUNTER FREEZERS

Model	Door/Drawers	# of Shelves	HP	Amps	Crated Weight lb. (kg.)	Cabinet Dimensions W D† H* (in)	Cabinet Dimensions W D† H* (mm)
SOLID DOORS							
TUC-44F-HC	1/0	2	½	5.8	285 (130)	44 ⁷ / ₈ x 32 ¹ / ₄ x 29 ³ / ₄	1138 x 820 x 756
TUC-60-32F-HC	2/0	4	½	5.8	415 (189)	60 ¹ / ₄ x 32 ¹ / ₄ x 29 ³ / ₄	1531 x 820 x 756
TUC-67F-HC	2/0	4	½	5.8	400 (182)	67 ¹ / ₄ x 32 ¹ / ₄ x 29 ³ / ₄	1709 x 820 x 756

† Depth does not include 1" (26mm) for rear bumpers or ¼"(7mm) for front bumper.

* Height does not include 6¼"(159mm) for castors or 6" (153mm) for optional legs.

note: Door/drawer combination cabinets require customer to designate door/drawer orientation.

Environmentally friendly R290 hydrocarbon refrigeration system for the best in food preservation.



Undercounter | TUC®~SPEC3

UNDERCOUNTER FREEZERS ~SPEC3 SERIES

Solid Doors & Drawers

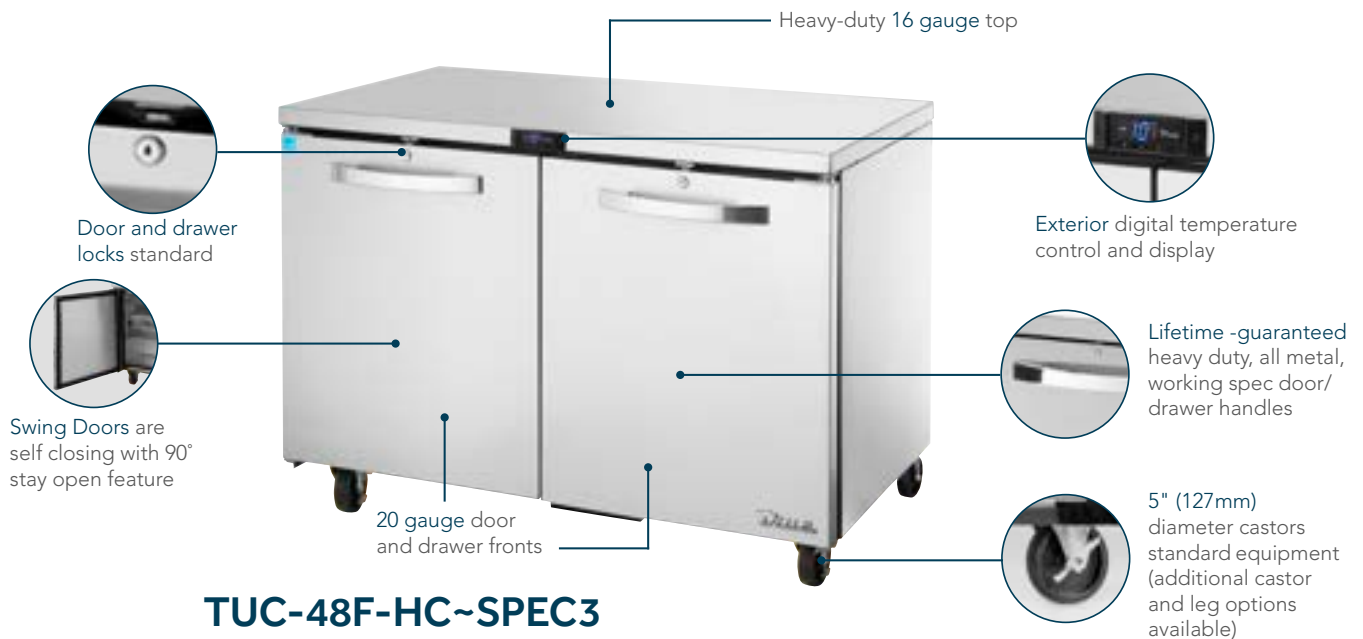

TUC-48F-HC~SPEC3



TUC-27F-HC~SPEC3



TUC-27F-D-2-HC~SPEC3



TUC-48F-D-4-HC~SPEC3



TUC-60F-HC~SPEC3

Features/Benefits

- Freezers maintain -10°F (-23.3°C) product temperatures.
- Automatic defrost system on freezer models time-initiated, time-terminated.
- All stainless steel front, countertop, sides and back.
- Interior features stainless steel liner and stainless steel floor with coved corners.
- Adjustable, heavy-duty, PVC-coated wire shelves (not available in drawer models).
- Doors swing within cabinet dimensions.
- Work surface 36" (915mm) high.
- Low profile models (31-7/8" (810mm) work surface height) upcharge applies or ADA compliant with 34" (864mm) work surface height available; no charge. (models -27, -36, -48, -60, -72).
- All production of True models comply with NSF/ANSI standard 7.
- Self-contained system.

Glass Door Model have...

- Energy efficient, "Low-E", double paned thermal insulated glass doors on refrigerator models (triple pane thermal insulated glass on freezer models).
- Extruded, aluminum door frames.
- LED interior lighting provides more even lighting throughout the cabinet. Safety shielded.

Drawer Models have...

- Standard depth models accommodate one 12" L x 20" W x 8" D (305mm x 508mm x 204mm) full size pan or four 1/2 pans or six 1/3 pans per drawer. Pans not included.
- Door/drawer combination models require customer to designate door/drawer orientation.



TUC® UNDERCOUNTER FREEZERS ~SPEC3 SERIES

Model	Door/Drawers	# of Shelves	HP	Amps	Crated Weight lb. (kg.)	Cabinet Dimensions W D† H* (in)	Cabinet Dimensions W D† H* (mm)
SOLID DOORS							
TUC-27F-HC~SPEC3	1/0	2	¼	2.3	210 (96)	27½ x 29½ x 29¾	702 x 740 x 756
TUC-48F-HC~SPEC3	2/0	4	⅓	3.2	275 (125)	48¾ x 29½ x 29¾	1229 x 740 x 756
TUC-60F-HC~SPEC3	2/0	4	½	4.8	335 (152)	60¾ x 29½ x 29¾	1534 x 740 x 756
WITH DRAWERS							
TUC-27F-D-2-HC~SPEC3	0/2	N/A	¼	2.3	220 (100)	27½ x 29½ x 29¾	700 x 740 x 756
TUC-48F-D-4-HC~SPEC3	0/4	N/A	⅓	3.2	325 (148)	48¾ x 29½ x 29¾	1229 x 740 x 756

† Depth does not include 1¾" (45mm) for door handles.

† Depth does not include 1" (26mm) for rear bumpers or ¼" (7mm) for front bumper.

* Height does not include 6¼" (159mm) for castors or 6" (153mm) for optional legs.

note: Door/drawer combination cabinets require customer to designate door/drawer orientation.

Environmentally friendly R290 hydrocarbon refrigeration system for the best in food preservation.



Undercounter | TUC® Deep~SPEC3

UNDERCOUNTER DEEP FREEZERS ~SPEC3

Solid Doors



TUC-44F-HC~SPEC3



TUC-67F-HC~SPEC3

Features/Benefits

- Freezers maintain -10°F (-23.3°C) product temperatures.
- Automatic defrost system on freezer models time-initiated, time-terminated.
- Features the combined advantage of convenient undercounter placement with deeper refrigerated storage.
- All stainless steel front, countertop, sides and back.
- Interior features stainless steel liner and stainless steel floor with coved corners.
- Adjustable, heavy-duty, PVC-coated wire shelves (not available in drawer models).
- Doors swing within cabinet dimensions.
- Work surface 36" (915mm) high.

- Accommodates half bun tray rack; applies to only one door of TUC-60-32 (18" x 26" (458mm x 661mm) sheet pan) - not included.
- ADA compliant with 34" (864mm) work surface height available; no charge.
- All production of True models comply with NSF/ANSI standard 7.
- Self-contained system.

Drawer Models have...

- Accommodates one 12" L x 20" W x 8" D (305mm x 508mm x 204mm) full size pan or four 1/2 pans or six 1/3 pans per drawer. Pans not included.
- Door/drawer combination models require customer to designate door/drawer orientation.



TUC® DEEP UNDERCOUNTER FREEZERS ~SPEC3 SERIES

Model	Door/Drawers	# of Shelves	HP	Amps	Crated Weight lb. (kg.)	Cabinet Dimensions W D† H* (in)	Cabinet Dimensions W D† H* (mm)
SOLID DOORS							
TUC-44F-HC~SPEC3	1/0	2	½	5.8	285 (130)	44 ⁷ / ₈ x 32 ¹ / ₄ x 29 ³ / ₄	1138 x 818 x 765
TUC-60-32F-HC~SPEC3	2/0	4	½	5.8	415 (189)	60 ¹ / ₄ x 32 ¹ / ₄ x 29 ³ / ₄	1531 x 818 x 765
TUC-67F-HC~SPEC3	2/0	4	½	5.8	430 (196)	67 ¹ / ₄ x 32 ¹ / ₄ x 29 ³ / ₄	1709 x 818 x 765

† Depth does not include 1" (26mm) for rear bumpers or ¼" (7mm) for front bumper.

* Height does not include 6¼" (159mm) for castors or 6" (153mm) for optional legs.

note: Door/drawer combination cabinets require customer to designate door/drawer orientation.

Environmentally friendly R290 hydrocarbon refrigeration system for the best in food preservation.



Undercounter | TUC® (ADA & LP)

AMERICAN DISABILITY ACT (ADA) COMPLIANT & LOW PROFILE (LP) PACKAGES

Solid Doors & Drawers



ADA models feature 3" (77mm) diameter castors



TUC-27-HC



LP models feature 1-½" (39mm) diameter, dual swivel castors



TUC-27-HC

Features/Benefits

ADA Models...

- True undercounter units are designed to accommodate American Disabilities Act (ADA) requirements.
- ADA Compliant models have 3" (127mm) castors
- ADA Compliant models have 34" (864mm) counter heights.

LP Models...

- "Low Profile" models are designed to slide easily under custom built countertops.
- Low profile models have 1-1/2" (39mm) castors
- Low profile models have 31-7/8" (810mm) work surface heights.

UNDERCOUNTER

True Undercounter Units Are Designed To Accommodate American Disabilities Act (ADA) Requirements.

PLAN VIEW COMPARISON

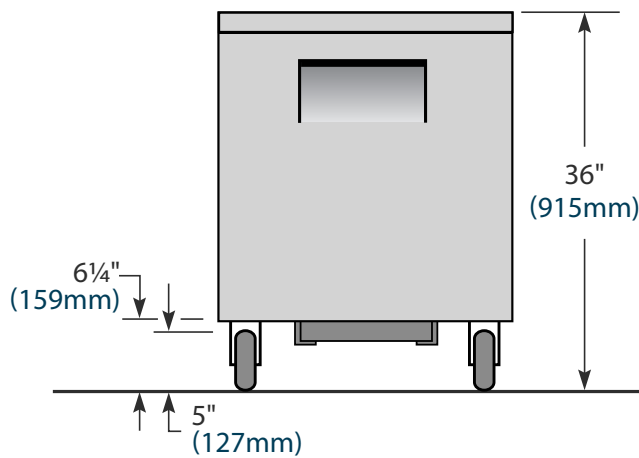

Standard

36" (915mm) Height

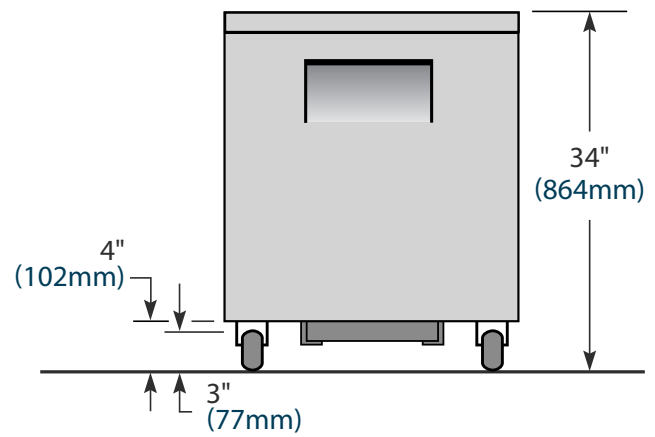

ADA Compliant

34" (864mm) Height

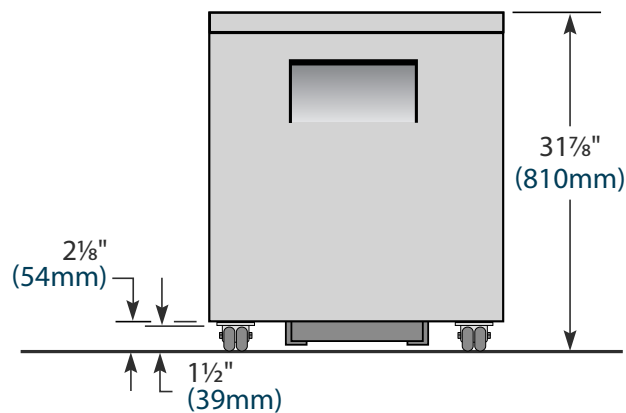

Low Profile

31-7/8" (810mm) Height



WORKTOP REFRIGERATION

Worktop refrigerators provide a functional work surface as well as a one-piece formed construction stainless backsplash and 360° circular airflow for the most efficient and uniform product cooling.





WORKTOP REFRIGERATORS

Solid Doors & Drawers



TWT-27D-2-HC



TWT-27F-HC



TWT-60D-4-HC



TWT-72-HC

Features/Benefits

- Refrigerators maintain cold 33°F to 38°F (0.5°C to 3.3°C) product temperatures.
 - All stainless steel front, top and sides.
 - Corrosion resistant GalFan coated steel back.
 - Interior - attractive, clear aluminum sides and top, coved corners and stainless steel floor.
 - One piece formed construction backsplash prevents bacteria and food particles from being trapped underneath as with other two piece worktop units
 - Recessed handles
 - Adjustable, heavy-duty, PVC-coated wire shelves (not available in drawered models).
 - Work surface 36" (915mm) high.
 - Swing doors are self-closing with 90° stay open feature.
 - ADA compliant with 34" (864mm) work surface height available; no charge. (models -27, -36, -48, -60, -72).
 - All production of True models comply with NSF/ANSI standard 7.
 - Self-contained system.
- Drawer Models have...**
- Accommodates one 12"L x 20"W x 6"D (305mm x 508mm x 153mm) full size pan or two 1/2 pans or three 1/3 pans per drawer. (48" (1,220mm) models accommodate one 12"L x 18"W x 6"D (305mm x 408mm x 153mm) food storage box or one 1/3 size and one 1/2 size pan per drawer; not included).
 - Door/drawer combination models require customer to designate door/drawer orientation.



TWT™ WORKTOP REFRIGERATORS

Model	Door/Drawers	# of Shelves	HP	Amps	Crated Weight lb. (kg.)	Cabinet Dimensions W D† H* (in)	Cabinet Dimensions W D† H* (mm)
SOLID DOORS							
TWT-27-HC	1/0	2	1/6	2.0	195 (89)	27 ³ / ₈ x 30 ¹ / ₈ x 33 ³ / ₈	702 x 766 x 848
TWT-36-HC	2/0	4	1/6	2.0	240 (109)	36 ³ / ₈ x 30 ¹ / ₈ x 33 ³ / ₈	924 x 766 x 848
TWT-48-HC	2/0	4	1/5	2.0	280 (128)	48 ³ / ₈ x 30 ¹ / ₈ x 33 ³ / ₈	1229 x 766 x 848
TWT-60-HC	2/0	4	1/4	4.0	345 (157)	60 ³ / ₈ x 30 ¹ / ₈ x 33 ³ / ₈	1534 x 766 x 848
TWT-72-HC	3/0	6	1/4	4.0	405 (184)	72 ³ / ₈ x 30 ¹ / ₈ x 33 ³ / ₈	1839 x 766 x 848
WITH DRAWERS OR DOOR/DRAWER COMBO							
TWT-27D-2-HC	0/2	N/A	1/6	2.0	215 (98)	27 ³ / ₈ x 30 ¹ / ₈ x 33 ³ / ₈	702 x 766 x 848
TWT-48D-2-HC	1/2	2	1/5	3.0	330 (150)	48 ³ / ₈ x 30 ¹ / ₈ x 33 ³ / ₈	1229 x 766 x 848
TWT-48D-4-HC	0/4	N/A	1/5	3.0	330 (150)	48 ³ / ₈ x 30 ¹ / ₈ x 33 ³ / ₈	1229 x 766 x 848
TWT-60D-2-HC	1/2	2	1/4	4.0	345 (157)	60 ³ / ₈ x 30 ¹ / ₈ x 33 ³ / ₈	1534 x 766 x 848
TWT-60D-4-HC	0/4	N/A	1/4	4.0	410 (186)	60 ³ / ₈ x 30 ¹ / ₈ x 33 ³ / ₈	1534 x 766 x 848

† Depth does not include 1" (26mm) for rear bumpers.

* Height does not include 6¹/₄" (159mm) for castors or 6" (153mm) for optional legs.

note: Door/drawer combination cabinets require customer to designate door/drawer orientation.

Environmentally friendly R290 hydrocarbon refrigeration system for the best in food preservation.



WORKTOP DEEP REFRIGERATORS

Solid Doors & Drawers



TWT-67D-2-HC



TWT-44F-HC



TWT-60-32D-2-HC



TWT-67D-4-HC



TWT-93D-4-HC

Features/Benefits

- Refrigerators maintain cold 33°F to 38°F (0.5°C to 3.3°C) product temperatures.
 - All stainless steel front, top and sides.
 - Corrosion resistant GalFan coated steel back.
 - Interior - attractive, clear aluminum sides and top, coved corners and stainless steel floor.
 - One piece formed construction backsplash prevents bacteria and food particles from being trapped underneath as with other two piece worktop units.
 - 360° circular airflow for uniform product cooling.
 - Recessed handles.
 - Adjustable, heavy-duty, PVC-coated wire shelves (not available in drawered models).
 - Work surface 36" (915mm) high.
 - Swing doors are self-closing with 90° stay open feature.
 - Accommodates half bun tray rack; applies to only one door of TWT-60-32-HC (18" x 26" sheet pan (458mm x 661mm)) - not included.
 - ADA compliant with 34" (864mm) work surface height available; no charge. (models -27, -36, -48, -60, -72).
 - All production of True models comply with NSF/ANSI standard 7.
 - Self-contained system.
- Drawer Models have...**
- Accommodates one 12"L x 20"W x 8"D (305mm x 508mm x 204mm) full size pan or two 1/2 pans or three 1/3 pans per drawer. (48" (1,220mm) models accommodate one 12"L x 18"W x 6"D (305mm x 408mm x 153mm) food storage box or one 1/3 size and one 1/2 size pan per drawer; not included).
 - Door/drawer combination models require customer to designate door/drawer orientation.



TWT™ DEEP WORKTOP REFRIGERATORS

Model	Door/Drawers	# of Shelves	HP	Amps	Crated Weight lb. (kg.)	Cabinet Dimensions W D† H* (in)	Cabinet Dimensions W D† H* (mm)
SOLID DOORS							
TWT-44-HC	1/0	2	1/10	1.7	320 (130)	44½ x 32¾ x 33¾	1131 x 823 x 848
TWT-60-32-HC	2/0	4	1/10	1.7	415 (189)	60¼ x 32¾ x 33¾	1531 x 823 x 848
TWT-67-HC	2/0	4	1/10	1.7	410 (186)	67¼ x 32¾ x 33¾	1709 x 823 x 848
TWT-93-HC	3/0	6	1/5	2.2	550 (250)	93¼ x 32¾ x 33¾	2369 x 823 x 848
WITH DRAWERS OR DOOR/DRAWER COMBO							
TWT-44D-2-HC	0/2	N/A	1/10	1.7	320 (146)	44½ x 32¾ x 33¾	1131 x 823 x 848
TWT-60-32D-2-HC	1/2	2	1/10	1.7	415 (189)	60¼ x 32¾ x 33¾	1531 x 823 x 848
TWT-67D-2-HC	1/2	2	1/10	1.7	430 (196)	67¼ x 32¾ x 33¾	1709 x 823 x 848
TWT-67D-4-HC	0/4	N/A	1/10	1.7	500 (186)	67¼ x 32¾ x 33¾	1709 x 823 x 848
TWT-93D-2-HC	2/2	4	1/5	2.2	580 (264)	93¼ x 32¾ x 33¾	2369 x 823 x 848
TWT-93D-4-HC	1/4	2	1/5	2.2	580 (264)	93¼ x 32¾ x 33¾	2369 x 823 x 848
TWT-93D-6-HC	0/6	N/A	1/5	2.2	550 (250)	93¼ x 32¾ x 33¾	2369 x 823 x 848

† Depth does not include 1" (26mm) for rear bumpers or ¼" (7mm) for front bumper.

* Height does not include 6¼" (159mm) for castors or 6" (153mm) for optional legs.

note: Door/drawer combination cabinets require customer to designate door/drawer orientation.

Environmentally friendly R290 hydrocarbon refrigeration system for the best in food preservation.



WORKTOP REFRIGERATORS ~SPEC3 SERIES

Solid Doors & Drawers



TWT-48D-2-HC~SPEC3



TWT-27F-HC~SPEC3



TWT-27D-2-HC~SPEC3



TWT-60D-2-HC~SPEC3



TWT-72-HC~SPEC3

Features/Benefits

- Refrigerators maintain cold 33°F to 38°F (0.5°C to 3.3°C) product temperatures.
 - All stainless steel front, countertop, sides, and back.
 - Interior - attractive, clear aluminum sides and top, coved corners and stainless steel floor.
 - One piece formed construction backsplash prevents bacteria and food particles from being trapped underneath as with other two piece worktop units
 - Adjustable, heavy-duty, PVC-coated wire shelves (not available in drawered models).
 - Heavy-duty 16 gauge top and 20 gauge door and drawer fronts.
 - Work surface 36" (915mm) high.
 - Swing doors are self-closing with 90° stay open feature.
 - ADA compliant with 34" (864mm) work surface height available; no charge. (models -27, -36, -48, -60, -72).
 - All production of True models comply with NSF/ANSI standard 7.
 - Self-contained system.
- Drawer Models have...**
- Accommodates one 12" L x 20" W x 6" D (305mm x 508mm x 153mm) full size pan or two 1/2 pans or three 1/3 pans per drawer. (48" (1,220mm) models accommodate one 12" L x 18" W x 6" D (305mm x 408mm x 153mm) food storage box or one 1/3 size and one 1/2 size pan per drawer; not included).
 - Door/drawer combination models require customer to designate door/drawer orientation.



TWT™ WORKTOP REFRIGERATORS ~SPEC3 SERIES

Model	Door/Drawers	# of Shelves	HP	Amps	Crated Weight lb. (kg.)	Cabinet Dimensions W D† H* (in)	Cabinet Dimensions W D† H* (mm)
SOLID DOORS							
TWT-27-HC~SPEC3	1/0	2	1/6	2.0	195 (89)	27 ⁵ / ₈ x 29 ¹ / ₈ x 33 ¹ / ₄	702 x 740 x 845
TWT-36-HC~SPEC3	2/0	4	1/6	2.0	240 (109)	36 ³ / ₈ x 29 ¹ / ₈ x 33 ¹ / ₄	924 x 740 x 845
TWT-48-HC~SPEC3	2/0	4	1/5	2.0	280 (128)	48 ³ / ₈ x 29 ¹ / ₈ x 33 ¹ / ₄	1229 x 740 x 845
TWT-60-HC~SPEC3	2/0	4	1/4	4.0	345 (157)	60 ³ / ₈ x 29 ¹ / ₈ x 33 ¹ / ₄	1534 x 740 x 845
TWT-72-HC~SPEC3	3/0	6	1/4	4.0	405 (184)	72 ³ / ₈ x 29 ¹ / ₈ x 33 ¹ / ₄	1839 x 740 x 845
WITH DRAWERS OR DOOR/DRAWER COMBO							
TWT-27D-2-HC~SPEC3	0/2	N/A	1/6	2.0	195 (89)	27 ⁵ / ₈ x 29 ¹ / ₈ x 33 ¹ / ₄	702 x 740 x 845
TWT-48D-2-HC~SPEC3	1/2	2	1/5	3.0	330 (150)	48 ³ / ₈ x 29 ¹ / ₈ x 33 ¹ / ₄	1229 x 740 x 845
TWT-48D-4-HC~SPEC3	0/4	N/A	1/5	3.0	330 (150)	48 ³ / ₈ x 29 ¹ / ₈ x 33 ¹ / ₄	1229 x 740 x 845
TWT-60D-2-HC~SPEC3	1/2	2	1/4	4.0	345 (157)	60 ³ / ₈ x 29 ¹ / ₈ x 33 ¹ / ₄	1534 x 740 x 845
TWT-60D-4-HC~SPEC3	0/4	N/A	1/4	4.0	410 (186)	60 ³ / ₈ x 29 ¹ / ₈ x 33 ¹ / ₄	1534 x 740 x 845

† Depth does not include 1 1/2" (39 mm) for door handles.

† Depth does not include 1" (26mm) for rear bumpers.

* Height does not include 6 1/4" (159mm) for castors or 6" (153mm) for optional legs.

note: Door/drawer combination cabinets require customer to designate door/drawer orientation.

Environmentally friendly R290 hydrocarbon refrigeration system for the best in food preservation.



All dimensions are rounded up to the nearest 1/8" (whole millimeter) | Specifications subject to change without notice.

WORKTOP DEEP REFRIGERATORS ~SPEC3 SERIES

Solid Doors & Drawers



TWT-67D-2-HC~SPEC3



TWT-44D-2-HC-SPEC3



TWT-44-HC-SPEC3



TWT-60-32F-HC-SPEC3



TWT-93D-6-HC-SPEC3

Features/Benefits

- Refrigerators maintain cold 33°F to 38°F (0.5°C to 3.3°C) product temperatures.
 - All stainless steel front, countertop, sides and back.
 - Interior - attractive, clear aluminum sides and top, coved corners and stainless steel floor.
 - One piece formed construction backsplash prevents bacteria and food particles from being trapped underneath as with other two piece worktop units.
 - 360° circular airflow for uniform product cooling.
 - Adjustable, heavy-duty, PVC-coated wire shelves (not available in drawered models).
 - Heavy-duty 16 gauge top and 20 gauge door and drawer fronts.
 - Work surface 36" (915mm) high.
 - Swing doors are self-closing with 90° stay open feature.
 - Accommodates half bun tray rack; applies to only one door of TWT-60-32-HC (18" x 26" sheet pan (458mm x 661mm)) - not included.
 - ADA compliant with 34" (864mm) work surface height available; no charge. (models -27, -36, -48, -60, -72).
 - All production of True models comply with NSF/ANSI standard 7.
 - Self-contained system.
- Drawer Models have...**
- Accommodates one 12"L x 20"W x 8"D (305mm x 508mm x 204mm) full size pan or two 1/2 pans or three 1/3 pans per drawer. (48" (1,220mm) models accommodate one 12"L x 18"W x 6"D (305mm x 408mm x 153mm) food storage box or one 1/3 size and one 1/2 size pan per drawer; not included).
 - Door/drawer combination models require customer to designate door/drawer orientation.



TWT™ DEEP WORKTOP REFRIGERATORS ~SPEC3 SERIES

Model	Door/Drawers	# of Shelves	HP	Amps	Crated Weight lb. (kg.)	Cabinet Dimensions W D† H* (in)	Cabinet Dimensions W D† H* (mm)
SOLID DOORS							
TWT-44-HC~SPEC3	1/0	2	1/10	1.7	320 (146)	44 7/8 x 32 1/4 x 33 1/4	1138 x 820 x 845
TWT-60-32-HC~SPEC3	2/0	4	1/10	1.7	415 (189)	60 1/4 x 32 1/4 x 33 1/4	1531 x 820 x 845
TWT-67-HC~SPEC3	2/0	4	1/10	1.7	410 (186)	67 1/4 x 32 1/4 x 33 1/4	1709 x 820 x 845
TWT-93-HC~SPEC3	3/0	6	1/5	2.2	550 (250)	93 1/4 x 32 1/4 x 33 1/4	2369 x 820 x 845
WITH DRAWERS OR DOOR/DRAWER COMBO							
TWT-44D-2-HC~SPEC3	0/2	N/A	1/10	1.7	320 (146)	44 7/8 x 32 1/4 x 33 1/4	1138 x 820 x 845
TWT-60-32D-2-HC~SPEC3	1/2	2	1/10	1.7	415 (189)	60 1/4 x 32 1/4 x 33 1/4	1531 x 820 x 845
TWT-67D-2-HC~SPEC3	1/2	2	1/10	1.7	430 (196)	67 1/4 x 32 1/4 x 33 1/4	1709 x 820 x 845
TWT-67D-4-HC~SPEC3	0/4	N/A	1/10	1.7	500 (227)	67 1/4 x 32 1/4 x 33 1/4	1709 x 820 x 845
TWT-93D-2-HC~SPEC3	2/2	4	1/5	2.2	580 (264)	93 1/4 x 32 1/4 x 33 1/4	2369 x 820 x 845
TWT-93D-4-HC~SPEC3	1/4	2	1/5	2.2	580 (264)	93 1/4 x 32 1/4 x 33 1/4	2369 x 820 x 845
TWT-93D-6-HC~SPEC3	0/6	N/A	1/5	2.2	550 (250)	93 1/4 x 32 1/4 x 33 1/4	2369 x 820 x 845

† Depth does not include 1 1/2" (39 mm) for door handles.

‡ Depth does not include 1" (26mm) for rear bumpers or 1/4" (7mm) for front bumper.

* Height does not include 6 1/4" (159mm) for castors or 6" (153mm) for optional legs.

note: Door/drawer combination cabinets require customer to designate door/drawer orientation.

Environmentally friendly R290 hydrocarbon refrigeration system for the best in food preservation.



WORKTOP FREEZERS

Solid Doors



TWT-48F-HC



TWT-27F-HC



TWT-60F-HC

Features/Benefits

- Freezers maintain -10°F (-23.3°C) product temperatures.
- Automatic defrost system on freezer models time-initiated, time-terminated.
- All stainless steel front, top and sides.
- Corrosion resistant GalFan coated steel back.
- Interior - attractive, clear aluminum sides and top, coved corners and stainless steel floor.
- One piece formed construction backplash prevents bacteria and food particles from being trapped underneath as with other two piece worktop units
- Recessed handles
- Adjustable, heavy-duty, PVC-coated wire shelves (not available in drawered models).
- Work surface 36" (915mm) high.

- Swing doors are self-closing with 90° stay open feature.
- ADA compliant with 34" (864mm) work surface height available; no charge. (models -27, -36, -48, -60, -72).
- All production of True models comply with NSF/ANSI standard 7.
- Self-contained system.

Drawer Models have...

- Accommodates one 12"L x 20"W x 6"D (305mm x 508mm x 153mm) full size pan or two 1/2 pans or three 1/3 pans per drawer. (48" (1,220mm) models accommodate one 12"L x 18"W x 6"D (305mm x 408mm x 153mm) food storage box or one 1/3 size and one 1/2 size pan per drawer; not included).
- Door/drawer combination models require customer to designate door/drawer orientation.



TWT™ WORKTOP FREEZERS

Model	Door/Drawers	# of Shelves	HP	Amps	Crated Weight lb. (kg.)	Cabinet Dimensions W D† H* (in)	Cabinet Dimensions W D† H* (mm)
SOLID DOORS							
TWT-27F-HC	1/0	2	¼	2.3	210 (96)	27½ x 30½ x 33¾	702 x 766 x 848
TWT-48F-HC	2/0	4	⅓	3.2	285 (130)	48¾ x 30½ x 33¾	1229 x 766 x 848
TWT-60F-HC	2/0	4	½	4.8	375 (171)	60¾ x 30½ x 33¾	1534 x 766 x 848

† Depth does not include 1" (26mm) for rear bumpers.

* Height does not include 6¼" (159mm) for castors or 6" (153mm) for optional legs.

Environmentally friendly R290 hydrocarbon refrigeration system for the best in food preservation.



WORKTOP DEEP FREEZERS

Solid Doors



TWT-67F-HC



TWT-44F-HC



TWT-60-32F-HC

Features/Benefits

- Freezers maintain -10°F (-23.3°C) product temperatures.
 - Automatic defrost system on freezer models time-initiated, time-terminated.
 - All stainless steel front, top and sides.
 - Corrosion resistant GalFan coated steel back.
 - Interior - attractive, clear aluminum sides and top, coved corners and stainless steel floor.
 - One piece formed construction backsplash prevents bacteria and food particles from being trapped underneath as with other two piece worktop units.
 - 360° circular airflow for uniform product cooling.
 - Recessed handles.
 - Adjustable, heavy-duty, PVC-coated wire shelves (not available in drawered models).
 - Work surface 36" (915mm) high.
 - Swing doors are self-closing with 90° stay open feature.
 - Accommodates half bun tray rack; applies to only one door of TWT-60-32-HC (18" x 26" sheet pan (458mm x 661mm)) - not included.
 - ADA compliant with 34" (864mm) work surface height available; no charge. (models -27, -36, -48, -60, -72).
 - All production of True models comply with NSF/ANSI standard 7.
 - Self-contained system.
- Drawer Models have...**
- Accommodates one 12" L x 20" W x 8" D (305mm x 508mm x 204mm) full size pan or two 1/2 pans or three 1/3 pans per drawer. (48" (1,220mm) models accommodate one 12" L x 18" W x 6" D (305mm x 408mm x 153mm) food storage box or one 1/3 size and one 1/2 size pan per drawer; not included).
 - Door/drawer combination models require customer to designate door/drawer orientation.



TWT™ DEEP WORKTOP FREEZERS

Model	Door/Drawers	# of Shelves	HP	Amps	Crated Weight lb. (kg.)	Cabinet Dimensions W D† H* (in)	Cabinet Dimensions W D† H* (mm)
SOLID DOORS							
TWT-44F-HC	1/0	2	½	5.8	320 (146)	44½ x 32¾ x 33¾	1131 x 823 x 848
TWT-60-32F-HC	2/0	4	½	5.8	415 (189)	60¼ x 32¾ x 33¾	1531 x 823 x 848
TWT-67F-HC	2/0	4	½	5.8	440 (200)	67¼ x 32¾ x 33¾	1709 x 823 x 848

† Depth does not include 1" (26mm) for rear bumpers or ¼" (7mm) for front bumper.
 * Height does not include 6¼" (159mm) for castors or 6" (153mm) for optional legs.

Environmentally friendly R290 hydrocarbon refrigeration system for the best in food preservation.



WORKTOP FREEZERS ~SPEC3 SERIES

Solid Doors

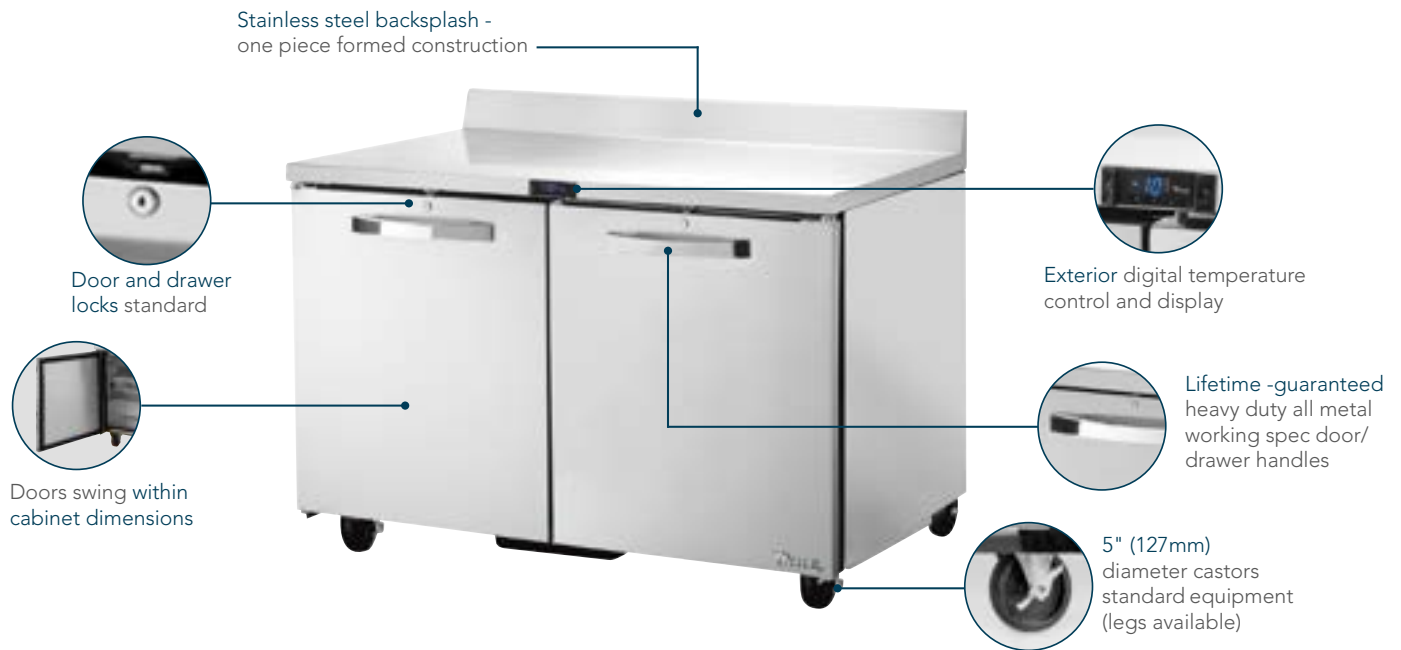

TWT-48F-HC~SPEC3



TWT-27F-HC~SPEC3



TWT-60D-2-HC~SPEC3

Features/Benefits

- Freezers maintain -10°F (-23.3°C) product temperatures.
- Automatic defrost system on freezer models time-initiated, time-terminated.
- All stainless steel front, countertop, sides, and back.
- Interior - attractive, clear aluminum sides and top, coved corners and stainless steel floor.
- One piece formed construction backsplash prevents bacteria and food particles from being trapped underneath as with other two piece worktop units
- Adjustable, heavy-duty, PVC-coated wire shelves (not available in drawer models).
- Heavy-duty 16 gauge top and 20 gauge door and drawer fronts.
- Work surface 36" (915mm) high.

- Swing doors are self-closing with 90° stay open feature.
- ADA compliant with 34" (864mm) work surface height available; no charge. (models -27, -36, -48, -60, -72).
- All production of True models comply with NSF/ANSI standard 7.
- Self-contained system.

Drawer Models have...

- Accommodates one 12" L x 20" W x 6" D (305mm x 508mm x 153mm) full size pan or two 1/2 pans or three 1/3 pans per drawer. (48" (1,220mm) models accommodate one 12" L x 18" W x 6" D (305mm x 408mm x 153mm) food storage box or one 1/3 size and one 1/2 size pan per drawer; not included).
- Door/drawer combination models require customer to designate door/drawer orientation.



TWT™ WORKTOP FREEZERS ~SPEC3 SERIES

Model	Door/Drawers	# of Shelves	HP	Amps	Crated Weight lb. (kg.)	Cabinet Dimensions W D† H* (in)	Cabinet Dimensions W D† H* (mm)
SOLID DOORS							
TWT-27F-HC~SPEC3	1/0	2	¼	2.3	210 (96)	27½ x 29½ x 33¼	702 x 740 x 845
TWT-48F-HC~SPEC3	2/0	4	⅓	3.2	285 (130)	48¾ x 29½ x 33¼	1229 x 740 x 845
TWT-60F-HC~SPEC3	2/0	4	½	4.8	375 (171)	60¾ x 29½ x 33¼	1534 x 740 x 845

† Depth does not include 1½" (39 mm) for door handles.

† Depth does not include 1" (26mm) for rear bumpers.

* Height does not include 6¼" (159mm) for castors or 6" (153mm) for optional legs.

Environmentally friendly R290 hydrocarbon refrigeration system for the best in food preservation.



WORKTOP DEEP FREEZERS ~SPEC3 SERIES

Solid Doors



TWT-44F-HC~SPEC3



TWT-60-32F-HC~SPEC3

Features/Benefits

- Freezers maintain -10°F (-23.3°C) product temperatures.
 - Automatic defrost system on freezer models time-initiated, time-terminated.
 - All stainless steel front, countertop, sides and back.
 - Interior - attractive, clear aluminum sides and top, coved corners and stainless steel floor.
 - One piece formed construction backsplash prevents bacteria and food particles from being trapped underneath as with other two piece worktop units.
 - 360° circular airflow for uniform product cooling.
 - Adjustable, heavy-duty, PVC-coated wire shelves (not available in drawered models).
 - Heavy-duty 16 gauge top and 20 gauge door and drawer fronts.
 - Work surface 36" (915mm) high.
 - Swing doors are self-closing with 90° stay open feature.
 - Accommodates half bun tray rack; applies to only one door of TWT-60-32-HC (18" x 26" sheet pan (458mm x 661mm)) - not included.
 - ADA compliant with 34" (864mm) work surface height available; no charge. (models -27, -36, -48, -60, -72).
 - All production of True models comply with NSF/ANSI standard 7.
 - Self-contained system.
- Drawer Models have...**
- Accommodates one 12" L x 20" W x 8" D (305mm x 508mm x 204mm) full size pan or two 1/2 pans or three 1/3 pans per drawer. (48" (1,220mm) models accommodate one 12" L x 18" W x 6" D (305mm x 408mm x 153mm) food storage box or one 1/3 size and one 1/2 size pan per drawer; not included).
 - Door/drawer combination models require customer to designate door/drawer orientation.



TWT™ DEEP WORKTOP FREEZERS ~SPEC3 SERIES

Model	Door/Drawers	# of Shelves	HP	Amps	Crated Weight lb. (kg.)	Cabinet Dimensions W D† H* (in)	Cabinet Dimensions W D† H* (mm)
SOLID DOORS							
TWT-44F-HC~SPEC3	1/0	2	½	5.8	320 (146)	44¾ x 32¼ x 33¼	1138 x 820 x 845
TWT-60-32F-HC~SPEC3	2/0	4	½	5.8	415 (189)	60¼ x 32¼ x 33¼	1531 x 820 x 845
TWT-67F-HC~SPEC3	2/0	4	½	5.8	440 (200)	67¼ x 32¼ x 33¼	1709 x 820 x 845

† Depth does not include 1½" (39 mm) for door handles.

† Depth does not include 1" (26mm) for rear bumpers.

* Height does not include 6¼" (159mm) for castors or 6" (153mm) for optional legs.

Environmentally friendly R290 hydrocarbon refrigeration system for the best in food preservation.



AMERICAN DISABILITY ACT (ADA) COMPLIANT PACKAGES

Solid Doors & Drawers



ADA models feature 3" (77mm) diameter castors

TWT-48-HC

Features/Benefits

- True worktop units are designed to accommodate American Disabilities Act (ADA) requirements.
- ADA Compliant models have 3" (127mm) castors
- ADA Compliant models have 34" (864mm) counter heights.

True Worktop Units Are Designed To Accommodate American Disabilities Act (ADA) Requirements.

PLAN VIEW COMPARISON

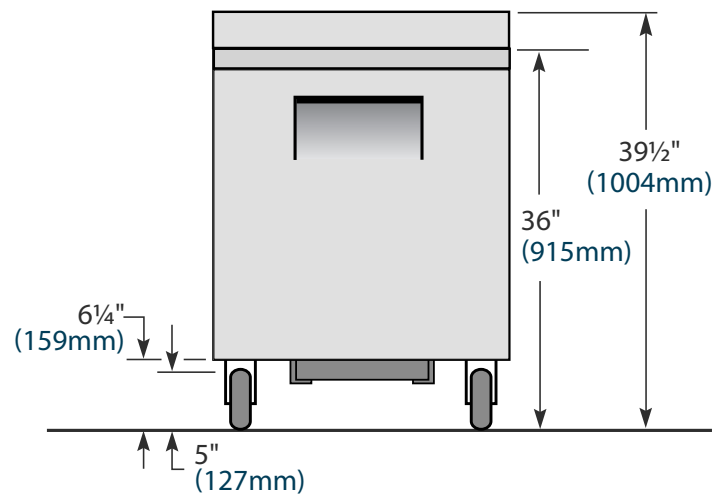

Standard

36" (915mm) Height

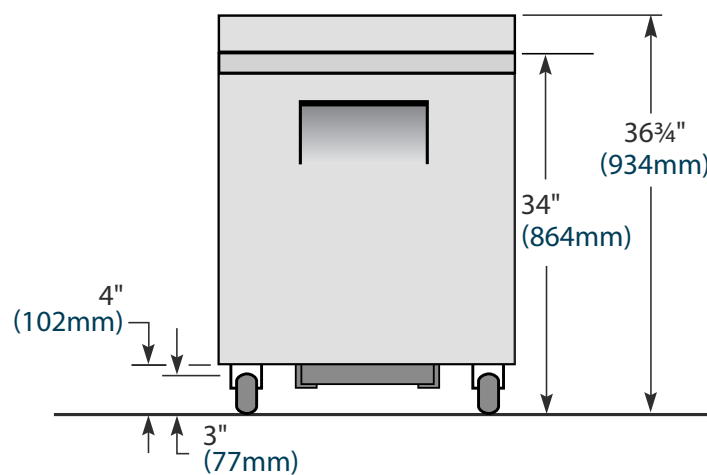

ADA Compliant

34" (864mm) Height



UNDERCOUNTER & WORKTOP REFRIGERATION

The kitchen worktop is where your creations come to life. When it's time to prep your customer's favorites, you can rely on True to streamline your operations. Our variety of model options are flexible to meet your needs – whether you need a unit that slides under an existing countertop, or you're in need of a functional work surface for smooth operations.