



TSCI-1200R-G-PH~TSL01



TSCI-150PR-SWG-R-WW_1A

⚠ WARNING!



Be sure to read and fully understand this document before installing, operating, maintaining or servicing this appliance. Failure to do so can result in appliance failure, property damage, serious injury or death. Appliance failure, injury or property damage due to improper installation is not covered by warranty.

📌 USER ACTION!

TRUE tracks the history of your appliance by its serial number. For easy reference, record your appliances full model name and serial number below. This information is on your serial label. Serial label location varies by appliance.

Model Name:

Serial Number:

True Manufacturing Co., Inc.

2001 East Terra Lane • O'Fallon, Missouri 63366-4434
(636) 240-2400 • FAX: (636)-272-2408

International FAX: (636)-272-7546 • (800)-325-6152

Parts Department: (800)-424-TRUE (424-8783)
Parts Department FAX: (636)-272-9471



INSTALLATION MANUAL
SCIENTIFIC SERIES
Original Instructions

North America – Canada and Caribbean

Warranty Phone +1 855-878-9277
Warranty Fax +1 636-980-8510
Warranty Email warrantyinquiries@truemfg.com
Technical Phone +1 855-372-1368
Technical Email service@truemfg.com
7:00 am–6:00 pm CST Monday–Friday,
8:00 am–12:00 pm Saturday

Mexico

Phone +52 555-804-6343/44
service-mexicocity@truemfg.com
9:00 am–5:30 pm M–F

Latin America

Phone: +52 555-804-6343/44
servicelatam@truemfg.com
9:00 am–5:30 pm M–F

UK, Ireland, Middle East, Africa & India

Phone: +44 (0) 800-783-2049
Service-emea@truemfg.com
8:30 am–5:00 pm M–F

Australia

Phone: +61 2-9618-9999
service-aus@truemfg.com
8:30 am–5:00 pm M–F

European Union & Commonwealth of Independent States

Phone: +41 61 563 0705
service-emea@truemfg.com
8:00 am–5:00 pm M–F



THANK YOU

FOR YOUR PURCHASE

Congratulations!

The primary purpose of this document is to assist the installation, maintenance, and servicing of your TRUE appliance. This document contains information important to safety, operation, maintenance, and servicing. **DO NOT** discard this document. TRUE is solely the appliance manufacturer. For assistance finding a qualified technician, please visit our Service Company Locator at truemfg.com/support/service-locator.

NOTICE!

Your appliance may not exactly match the figures shown in this manual.

Contents





Preface	
Signal & Symbol Definitions	3
Important Safety Information	
Basic Safety & Operation Warnings	4
Personal Injury Warnings	5
Hydrocarbon Refrigerant Warnings	6
Appliance Disposal Warnings	6
Electrical Safety Warnings	7
About Your Appliance & Installation Requirements	
Appliance Specifications	8
Clearances	8
Electrical Requirements	9
Electrical Installation & Safety	9
Installation & Setup	
Uncrating (Upright)	10
Uncrating (Undercounter)	12
Appliance Location	14
Install Leveling Legs or Castors	14
Level the Appliance	16
Seal the Appliance to the Floor	16
Battery Backup	17
Glycol Bottle & Temperature Probe	18
Shelf Installation	19
Optional Scientific Accessories	20
Remote Alarm Contact Location	22
Appliance Operation	
Startup	24
Recommended Startup Procedure	24
Temperature Control & Light Switch Location	25
Sequence of Operation	26
Electronic Temperature Control	
Display Code Definitions	28
Lock/Unlock the Control	29
Turn Off/On the Control	29
Change the Set Point	30
Change Defrost Intervals	30
Change Display Readout	31
Display Probe Temperatures	31
Temperature Alarms	32
Door Open Alarm	33
Adjust Temperature Alarm Ranges	33
High (thi) & Low (tLo) Temperature Log	35
Maintenance & Servicing	
Component Replacement	37
Recommended Maintenance	38
Condenser Coil Cleaning (Upright)	40
Condenser Coil Cleaning (Undercounter)	41
General Surface Care & Cleaning	42
Stainless Steel Care & Cleaning	43
8 Tips to Help Prevent Rust on Stainless Steel	44
Lock & Cam Replacement	45
Warranty	
Warranty Information	46









Preface









The warning, guidelines, and recommendations within this document are meant to prevent appliance damage, injury, or death. Please carefully read all warnings, guidelines, and recommendations before proceeding to ensure the continued safe use and maintenance of your TRUE appliance.

Signal & Symbol Definitions

Below are symbols you may see in this document. Some symbols may not appear.

Signal Word Definitions	
 DANGER!	An imminently hazardous situation which, if not avoided, will result in serious injury or death.
 WARNING!	A potentially hazardous situation which, if not avoided, can result in serious injury or death.
 CAUTION!	A potentially hazardous situation which, if not avoided, may result in minor or moderate injury; an unsafe practice.
 USER ACTION!	User action alert, follow all recommendations to avoid appliance or product damage.
 NOTICE!	Important information not related to hazards or risk of personal injury.

Safety Symbols	
	Safety alert; alerts reader to potential physical injury hazards. Obey all safety messages following this symbol to avoid possible injury or death.
	Flammable material; fire hazard.
	Electrical shock hazard.
	Tipping hazard; tip-over hazard.
	Sharp element; cut or sever hazard.
	Eye hazard; risk of eye injury.
	Exploding pressurized cylinder hazard.
	Slippery surface hazard.
	Crush or cut hazard.

Additional Symbols	
	Mandatory action alert symbol; alerts reader to required or recommended actions. Obey all messages and recommendations following this symbol to avoid appliance or product damage.
	Important information not related to hazards or risk of personal injury.
	Review and understand the installation manual before installing, operating, or servicing.
	Wear eye protection .
	Wear protective gloves .
	Secure gas cylinders to prevent falling cylinders.
	DO NOT use extension cord.
	DO NOT use adaptor plugs.
	DO NOT dispose of with other household waste.

Important Safety Information

Important Safety Information

Basic Safety & Operation Warnings

Follow basic safety precautions, including the following, to reduce risk of personal injury, electric shock, fire, or death.

⚠ WARNING!



Be sure to read and fully understand this document before installing, operating, maintaining, or servicing this appliance. Failure to do so can result in appliance failure, property damage, serious injury, or death. Appliance failure, personal injury, or property damage due to improper installation is not covered by warranty.

- Failure to install, operate, and maintain the appliance as detailed in this document will negatively affect safety, appliance performance, component life, and warranty coverage.
- The appliance must be installed in accordance with all applicable laws, codes, and regulations.
- The manufacturer cannot be held responsible for injury or damage resulting from improper, incorrect, and unreasonable use.
- This appliance is not to be used, cleaned, or maintained by persons (including children) with reduced physical, sensory, or mental capabilities or lack of experience and knowledge, without proper supervision or instruction.
- **DO NOT** install or operate equipment that has been misused, abused, neglected, damaged, or altered/modified from original manufactured specifications.
- **DO NOT** modify or alter the appliance. Improper alterations can result in electric shock, personal injury, fire, or death.
- Equipment cannot be operated inside the appliance if it is battery operated, plugged into an outlet other than the internal duplex outlet, OR has an ignition source (open contact switching, brushed AC and DC motors, etc.). Also, equipment must be rated to operate in ambient conditions that meet the internal environment of the appliance [2-10°C (35.6-50°F)].
- The appliance owner is responsible for performing a Personal Protective Equipment (PPE) Hazard Assessment and to ensure adequate protection during maintenance and cleaning procedures.
- Use appropriate tools, safety equipment, and PPE during installation and servicing.
- Only use the appliance for its intended purpose as described in this document. Failure to do so may result in equipment damage, personal injury, or death.
- Overloading, incorrectly installing, or improperly loading shelves can cause shelf failure (as well as negatively affect the appliance's operation), resulting in appliance damage, product damage, or personal injury.
- Keep the area surrounding the appliance clean to avoid appliance damage from debris or pests.

Important Safety Information (cont.)

Personal Injury Warnings

Only qualified technicians should install and service the appliance. For assistance finding a qualified technician, please visit our Service Company Locator at truemfg.com/support/service-locator. TRUE is solely the appliance manufacturer and is not responsible for installation.

⚠ DANGER!

	DO NOT allow children to play with or in the appliance. Child entrapment or personal injury can occur.
	DO NOT store or use the following in the vicinity of this or any other appliance: <ul style="list-style-type: none"> Gasoline or other flammable vapors and liquids Combustible or explosive substances, such as aerosol cans with a flammable propellant Other volatile or flammable substances
 	Contact TRUE Manufacturing to locate refrigerant lines and electrical wiring before drilling, cutting or puncturing interior or exterior walls. Failure to do so could result in damage, personal injury, or death.

⚠ WARNING!

	Only qualified technicians should install and service the appliance. <ul style="list-style-type: none"> Use appropriate tools, safety equipment, and personal protective equipment (PPE) during installation and servicing. DO NOT touch the cold surfaces in the freezer compartment when hands are damp or wet. Skin may stick to extremely cold surfaces.
	This product can expose you to chemicals including Di-(2-Ethyl hexyl) Phthalate (DEHP), which is known to the State of California to cause cancer and birth defects or other reproductive harm. For more information go to P65warnings.ca.gov .
	Slippery Surfaces! Moisture from improper drainage can create slippery surfaces near the appliance. It is your duty to immediately warn your customers of, and dry, the slippery surface. All wet floor areas must be marked with a wet floor sign.
	Sharp edges! Take care when moving, installing, cleaning, servicing, and maintaining the appliance to avoid cuts. Be sure to take care when reaching under the appliance or handling metal components. <ul style="list-style-type: none"> Keep fingers out of pinch point areas, such as the space between appliance doors and surrounding cabinetry. Take care closing doors with children nearby.
	Tip over hazard! Appliance may pose a tipping hazard when uncrating, installing, or moving the appliance. Take appropriate safety precautions. Use of tip over restraints may only reduce (not eliminate) the tipping hazard. Never allow children to climb or hang on drawers, doors, or shelves.
	Crush or cut hazard! Keep clear when uncrating, installing, moving, or servicing the appliance.
	Risk of electric shock or burn! See "Electrical Safety Warnings" for more information.

Important Safety Information (cont.)

Hydrocarbon Refrigerant Warnings

TRUE appliances use hydrocarbon refrigerant (R-290/513A/600a). Check the serial label to identify the appliance's refrigerant. Serial label location varies by model.

⚠ DANGER!



Risk of fire or explosion! Flammable refrigerant used.

- All servicing and maintenance must be performed by qualified technicians. This is to minimize the risk of fire or personal injury due to incorrect parts or improper service.
- Check the serial label to identify the appliance's refrigerant. Serial label location varies by model.
- **DO NOT** damage the refrigeration system during transportation and installation.
- If the appliance is damaged, verify the refrigeration system's integrity is not compromised before proceeding.
- Never use sharp objects or tools to remove ice or frost. **DO NOT** use mechanical devices to accelerate defrost.
- Dispose of in accordance with all applicable laws, codes, and regulations. Follow all safety precautions associated with handling flammable refrigerant.
- Equipment cannot be operated inside the appliance if it is battery operated, plugged into an outlet other than the internal duplex outlet, OR has an ignition source (open contact switching, brushed AC and DC motors, etc.). Also, equipment must be rated to operate in ambient conditions that meet the internal environment of the appliance [2-10°C (35.6-50°F)].

Appliance Disposal Warnings

⚠ DANGER!



Risk of child entrapment!

Children can get trapped inside discarded appliances and suffocate. Never dispose of your appliance without taking precautions to prevent child entrapment, even if the appliance only sits unattended for a short period of time.

Child entrapment precautions include the following:

- Remove all doors (or drawers for drawer appliances).
- Leave all interior drawers and shelving in place to make climbing (and fitting) inside the appliance more difficult.



Risk of fire or explosion! Flammable refrigerant and insulation used. Dispose of in accordance with all applicable laws, codes, and regulations. Follow all safety precautions associated with handling flammable refrigerant and insulation.









DO NOT dispose of your appliance with household waste.

Important Safety Information (cont.)

Electrical Safety Warnings

⚠ WARNING!

     	<p>Risk of electric shock, burn, or fire!</p> <ul style="list-style-type: none"> It is the appliance owner's responsibility to ensure the electrical connection meets all applicable building codes. Failure to meet these code requirements can result in appliance damage, fire, electric shock or burns, serious personal injury, or death. Before connecting your appliance to the power supply, verify the supply voltage and circuit rating match the appliance. Correct improper supply voltage or circuit size immediately. Before connecting your appliance to the power supply, verify the power supply is correctly grounded. If the power supply is not grounded, correct immediately. TRUE recommends hiring a qualified electrician to inspect your wall outlet and circuit to ensure they are properly grounded. DO NOT clean appliance with a pressure washer or hose. DO NOT immerse power cord in water. Powering off an electronic control or setting temperature controls to 0 (off position) does not remove power from all components. Unplug the appliance or turn off the power supply before installation or servicing. The appliance should receive power from its own individual dedicated electrical circuit. This provides the best performance and prevents overloading the power supply. The original equipment manufacturer (OEM) power cord has a grounding plug to minimize the possibility of electrical shock. <ul style="list-style-type: none"> Never remove the ground prong from the power cord! For personal safety, this appliance must be properly grounded. Never use an extension cord! An extension cord is any component that adds length to the OEM power cord when connecting the cord to a power source. Never use an adapter plug! An adapter plug alters the OEM plug configuration when connecting the plug to a power source. Never use a power cord that shows cracks or abrasion damage along its length or at either end. <ul style="list-style-type: none"> Immediately have a qualified technician replace damaged OEM power cords with OEM components. Never unplug your appliance by pulling on the power cord. Always grip the plug and pull the plug straight out of the outlet. Take care to prevent rolling over or damaging the power cord when moving the appliance. Never use the power cord to prevent appliance movement. Always use adequate means to keep the appliance in place without transmitting stress to the power cord. Keep power cord away from heated surfaces. DO NOT let power cord hang over edge of table or counter. DO NOT excessively bend or place heavy articles on the power cord.
---	--

ⓘ NOTICE!

	<p>TRUE will not warranty the following:</p> <ul style="list-style-type: none"> Compressor failures due to improper incoming voltage. Appliance with tampered OEM power cords. Appliance connected to adapters or extension cords. <p>For more details, see TRUE's full warranty statement.</p>
---	---

About Your Appliance & Installation Requirements

About Your Appliance & Installation Requirements

! USER ACTION!



TRUE is not responsible for damage incurred during shipment. Always carefully inspect for freight damage before receiving and installing your appliance. If there is damage, note all damage on the delivery receipt, immediately file a claim with the delivery freight carrier, and contact TRUE. **Do not install the appliance or put it in service.**

Thank you for choosing TRUE Manufacturing to meet your refrigeration needs. TRUE highly recommends a qualified technician and electrician install your appliance to ensure correct installation. The cost of professional installation is money well spent. Only qualified technicians should install and service the appliance.

For assistance finding a qualified technician, please visit our Service Company Locator at truemfg.com/support/service-locator. TRUE is solely the appliance manufacturer and is not responsible for installation.

The appliance owner is responsible for proper installation and maintaining the appliance as described in this document. Routine care and maintenance procedures are not covered by TRUE's warranty.

Appliance Specifications

Some things to know about your appliance are as follows:

- For proper operation, ambient temperatures shall not be less than 15°C (59°F) and no greater than 32°C (90°F).
- For proper operation, relative humidity shall not be greater than 60%.
- This appliance is restricted to altitudes below 2,000 m (6,512').
- This appliance is classified for use in a Pollution Degree 2 environment.
- Appliance is not suitable for outdoor use, unless otherwise stated on the serial label.
- Appliance is not suitable for an area where a pressure washer or hose may be used.

- Always plug the appliance into its own individual dedicated electrical circuit!
- **DO NOT** use extension cords or adapter plugs.
- Before connecting your appliance to the power supply, verify the incoming voltage ($\pm 5\%$) and the amps match the operation ratings on the appliance's serial label. Correct improper incoming voltage or amps immediately. Serial label location varies by model.
- Before connecting your appliance to the power supply, verify the power supply is correctly grounded. If the power supply is not grounded, correct immediately.
- Ensure the installation location will provide adequate clearances and sufficient airflow for the appliance. See "Clearances" pg 8.
- Read and follow all warnings and maintenance instructions. Failure to do so may result in damage and void the warranty on your appliance.

Clearances

! NOTICE!



Warranty is void if ventilation is insufficient.

Be sure your appliance has the required surrounding clearances for ventilation purposes. Keep all ventilation openings in the appliance enclosure or structure housing the appliance clear of obstruction.

MODEL	TOP	SIDES	BACK
TSCI Freezer	3" (76.2 mm)	0" (0 mm)	3" (76.2 mm)
TSCI Refrigerator	1" (25.4 mm)	0" (0 mm)	1" (25.4 mm)
TSCI Undercounter	0" (0 mm)	0" (0 mm)	0" (0 mm)

About Your Appliance & Installation Requirements (cont.)

Electrical Requirements

! USER ACTION!

!

Find a copy of the wiring diagram with our serial number lookup at truemfg.com/support/serial-number-lookup.

Wire gauge chart (115V)

115 Volts	Distance in Feet to Center of Load											
AMPS	20	30	40	50	60	70	80	90	100	120	140	160
2	14	14	14	14	14	14	14	14	14	14	14	14
3	14	14	14	14	14	14	14	14	14	14	14	12
4	14	14	14	14	14	14	14	14	14	12	12	12
5	14	14	14	14	14	14	14	12	12	12	10	10
6	14	14	14	14	14	14	12	12	12	10	10	10
7	14	14	14	14	14	12	12	12	10	10	10	8
8	14	14	14	14	12	12	12	10	10	10	8	8
9	14	14	14	12	12	12	10	10	10	8	8	8
10	14	14	14	12	12	10	10	10	10	8	8	8
12	14	14	12	12	10	10	10	8	8	8	8	6
14	12	12	12	10	10	10	8	8	8	6	6	6
16	12	12	12	10	10	8	8	8	8	6	6	6
18	12	12	10	10	8	8	8	8	8	8	8	5
20	12	12	10	10	8	8	8	6	6	6	5	5
25	10	10	10	8	8	6	6	6	6	5	4	4
30	10	10	8	8	6	6	6	6	5	4	4	3

Electrical Installation & Safety

NEMA Plug Configurations

60 HZ USE ONLY!

Your TRUE appliance uses the NEMA plug shown shown in fig. 1. If you **DO NOT** have the proper outlet, have a licensed electrician verify and install the correct power source.



Fig. 1. NEMA plug configuration.

Installation & Setup

Installation & Setup

⚠ WARNING!	
	Only qualified technicians should install and service the appliance. For assistance finding a qualified technician, please visit our Service Company Locator at truemfg.com/support/service-locator .
	The appliance owner is responsible for performing a Personal Protective Equipment (PPE) hazard Assessment and to ensure adequate protection during maintenance and cleaning procedures.
	Use appropriate tools , safety equipment, and PPE during installation and servicing.
	Sharp edges! Take care when moving, installing, cleaning, servicing and maintaining the appliance to avoid cuts. Be sure to take care when reaching under the appliance or handling metal components. Keep fingers out of pinch point areas, such as the space between appliance doors and surrounding appliances. Take care closing doors with children nearby.
	Risk of electrical shock or burn! Powering off an electronic control or setting temperature controls to the 0 (off) position does not remove power from all components. Unplug the appliance or turn off the power supply before installation or servicing.
	Tip over hazard! Appliance may pose a tipping hazard when uncrating, installing or moving the appliance. Take appropriate safety precautions. Use of tip over restraints may only reduce (not eliminate) the tipping hazard. Never allow children to climb or hang on drawers, doors or shelves.
	Crush or cut hazard! Keep clear when uncrating, installing, moving, or servicing the appliance.

Uncrating

ⓘ USER ACTION!	
	<ul style="list-style-type: none"> If the appliance is damaged, note all damage on the delivery receipt, immediately file a claim with the delivery freight carrier, and contact TRUE. DO NOT install the appliance or put it in service. If the appliance is laid on its back or side, be sure to leave the appliance upright twice the time it has been laying down (up to four (4) hours) before plugging the appliance into a power source. If this time exceeds four (4) hours, let the appliance sit upright for 24 hours before powering the appliance.
ⓘ NOTICE!	
	Keys for appliances with door locks are located in the warranty packet.

Required Tools

Required tools include (but may not be limited to) the following:

- Adjustable wrench
- Phillips screwdriver

Installation & Setup (cont.)

Procedure

1. Remove the outer packaging (cardboard and bubble wrap or Styrofoam corner and clear plastic). See fig. 1.

NOTICE > **DO NOT** remove the glass swing door shipping bracket (see fig. 2) until the unit is installed in its final location. **DO NOT DISCARD;** use the bracket when next moving the appliance.

2. With an adjustable wrench, remove all shipping bolts securing the wood skid to the bottom of the appliance. See fig. 3.

NOTICE > Move the appliance as close as possible to the final location before removing the wooden skid. Your model may require removing the front and/or rear grill/cover to access the shipping bolts.

3. If leveling legs or castors **will not be used**, remove the appliance from the wood skid and set the skid aside.

If leveling legs or castors **will be used**, rotate the appliance on the skid (see fig. 4) and see "Install Leveling Legs or Castors" (pg. 14).

NOTICE > **DO NOT** lift the appliance by the countertops, doors, drawers, or grills.

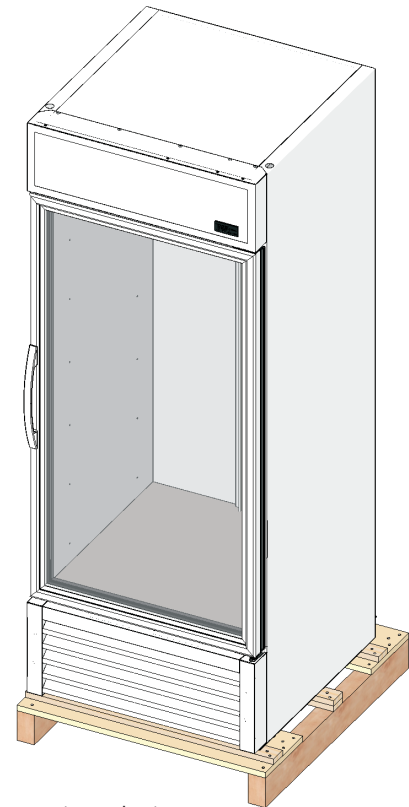

Fig. 1. Remove the exterior packaging.

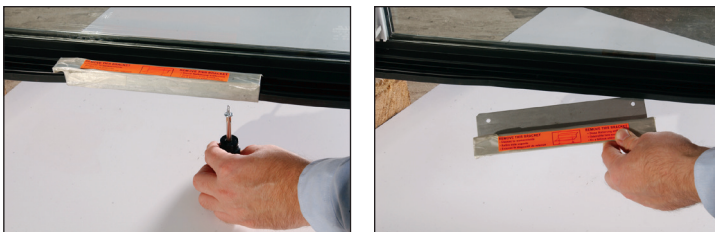

Fig. 2. Remove the glass swing door shipping bracket, if so equipped. Do not discard.

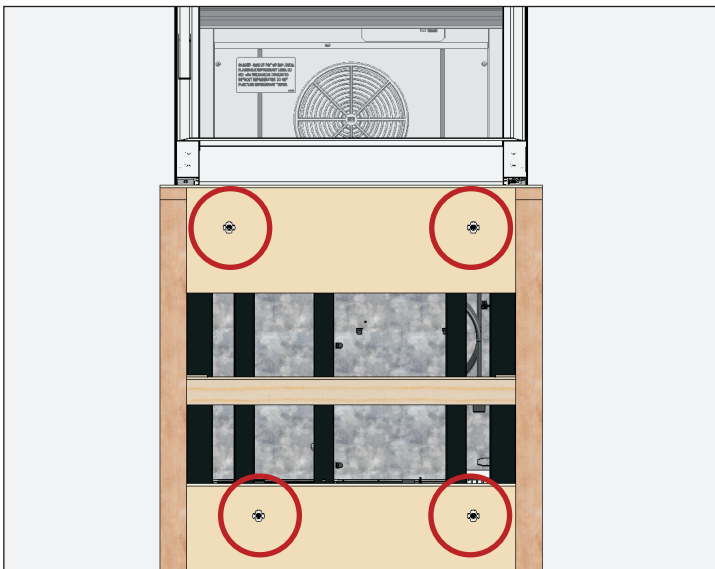

Fig. 3. Shipping bolt locations.

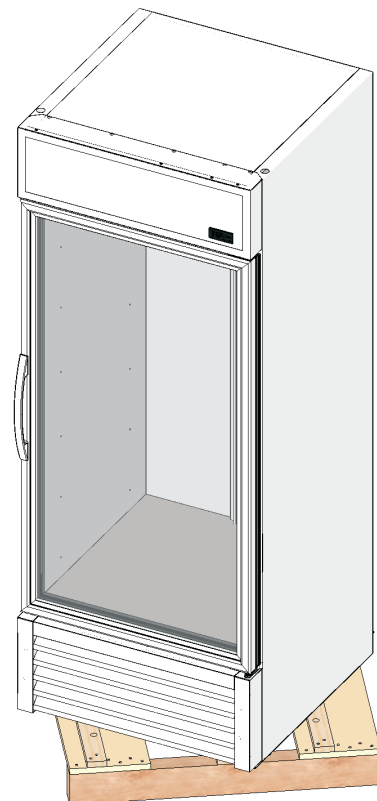

Fig. 4. When lifting the appliance, do not use countertops, doors, drawers, or grills as a lifting point.

Installation & Setup

Uncrating (Undercounter)

! USER ACTION!



- If the appliance is damaged, note all damage on the delivery receipt, immediately file a claim with the delivery freight carrier, and contact TRUE. **DO NOT install the unit or put it in service.**
- If the unit is laid on its back or side, be sure to leave the unit upright twice the time it has been laying down (up to four (4) hours) before plugging the unit into a power source. If this time exceeds four (4) hours, let the unit sit upright for 24 hours before powering the unit.

! NOTICE!



Keys for appliances with door locks are **located in the warranty packet.**

Required Tools

Required tools include (but may not be limited to) the following:

- Adjustable wrench
- Phillips screwdriver

Procedure

1. Remove the outer packaging (cardboard and bubble wrap or Styrofoam corner and clear plastic). See fig. 1.
2. With a Phillips screwdriver, remove the wooden door shipping block and shipping block bracket. See fig. 2.

NOTICE > Do not discard the wooden door shipping block; use the block when next moving the appliance.
3. With an adjustable wrench, remove all shipping bolts securing the wood skid to the bottom of the appliance. See fig. 3.

NOTICE > Move the unit as close as possible to the final location before removing the wooden skid. Some models may require removing the front and/or rear grill/cover to access the shipping bolts.
4. If leveling legs or castors **will not be used**, remove the appliance from the wood skid and set the skid aside.

If leveling legs or castors **will be used**, rotate the appliance on the skid (see fig. 4) and see "Install Leveling Legs or Castors" (pg. 14).

NOTICE > **DO NOT** lift the appliance by the countertops, doors, drawers, or grills.

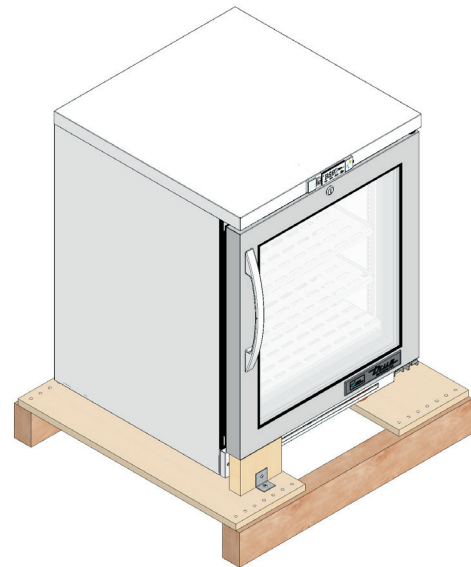

Fig. 1. Remove the exterior packaging.

Installation & Setup (cont.)

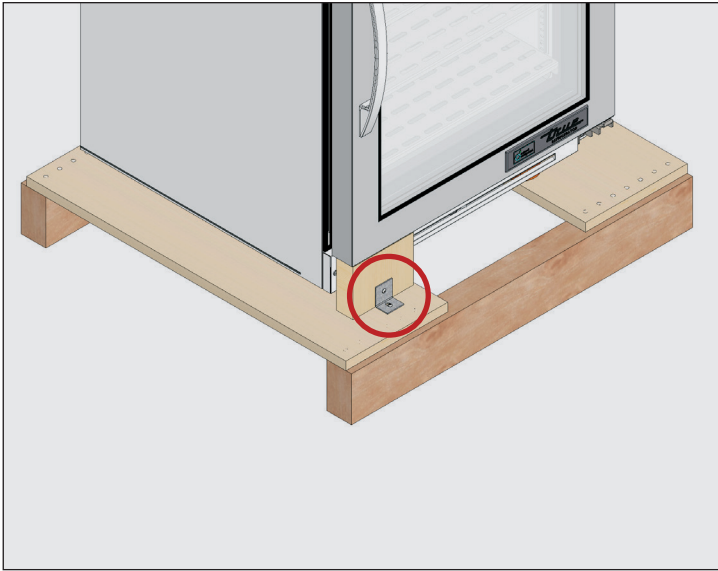

Fig. 2. Door shipping block and bracket location. Remove and **do not discard**.

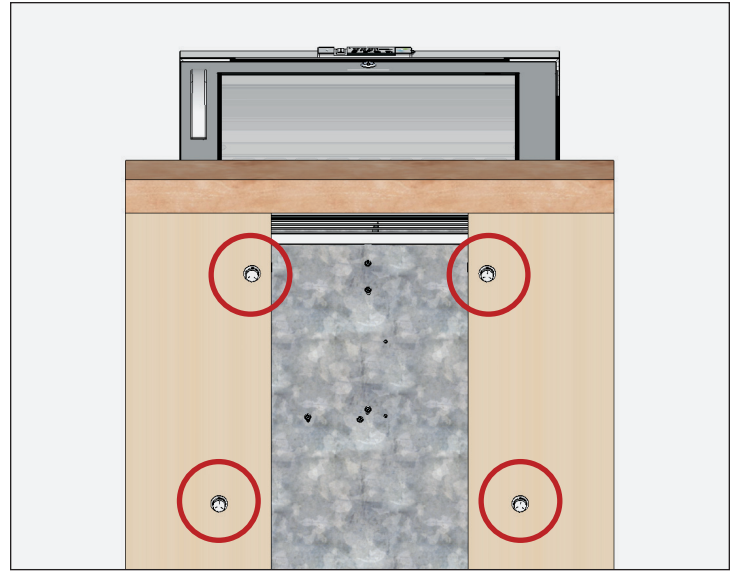

Fig. 3. Shipping bolt locations.

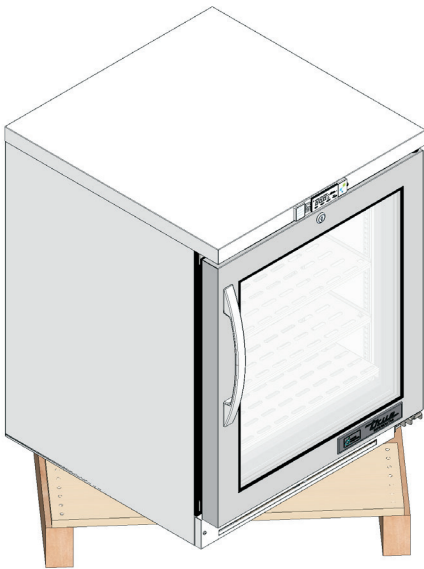

Fig. 4. When lifting the appliance, do not use countertops, doors, drawers, or grills as a lifting point.

Installation & Setup (cont.)

Appliance Location

- Ensure that the drain hose or hoses are positioned in the pan.
- Free the plug and cord from inside the lower rear of the appliance (**DO NOT** plug in).
- Place the appliance close enough to the electrical supply so that extension cords are never used.

Leveling Screw, Leg, or Castor Installation

⚠ WARNING!



Tipping hazard! ALWAYS verify center leveling screws fully contact the floor after leveling the appliance.

Leveling legs are provided to assist with leveling the appliance. Adjustable legs provide 6" (152 mm) of clearance under the appliance. Castors provide appliance mobility.

Required Tools

Required tools include (but may not be limited to) the following:

- Adjustable Wrench

Procedure – Leveling Screws

If leveling screws are not factory installed, then, with access to the appliance bottom, install the leveling screws into the threaded holes in the frame rail or appliance bottom. See figs. 1–3.

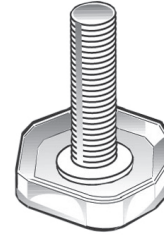

Fig. 1. Leveling screw.

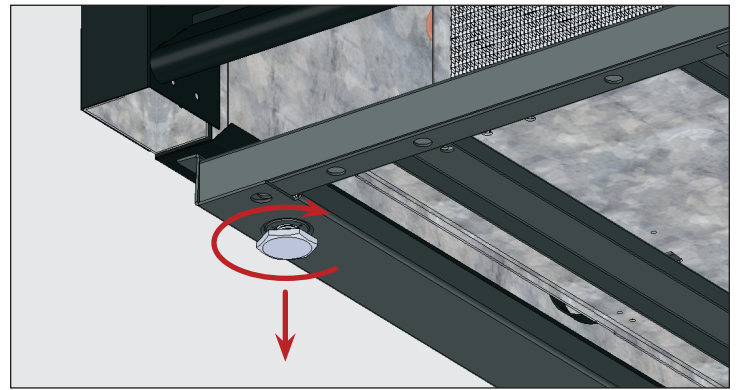

Fig. 2. Turn the leveling screws clockwise to lower the appliance.

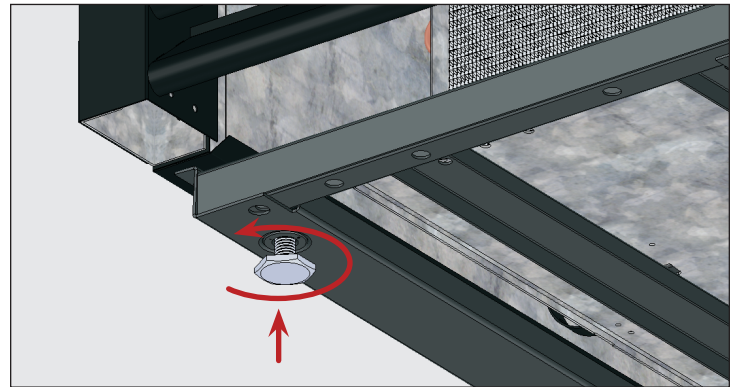

Fig. 3. Turn the leveling screws counterclockwise to raise the appliance.

Installation & Setup (cont.)

Procedure – 6" (152 mm) Leveling Legs

1. Access the appliance bottom.
2. If present, remove the leveling screws.
3. Thread the leveling legs into the frame rail or appliance bottom. See figs. 4 and 5.
4. Verify that the appliance is level. See "Level the Appliance" (pg. 16).
5. If the appliance is not level, gently lift and support the low end of the appliance. Then, with an adjustable wrench, screw the leveling leg bottom stems in or out to level and support the appliance. See fig. 4 and 6.

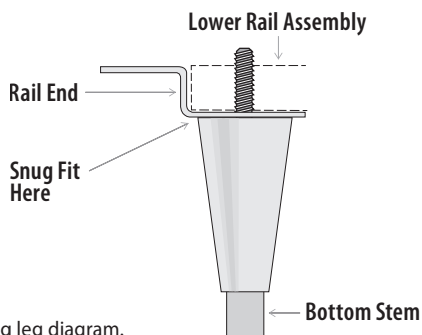

Fig. 4. Leveling leg diagram.

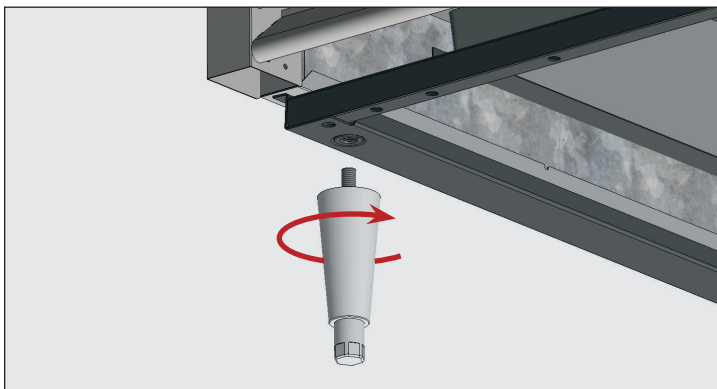

Fig. 5. Screw the leveling legs into the threaded holes.

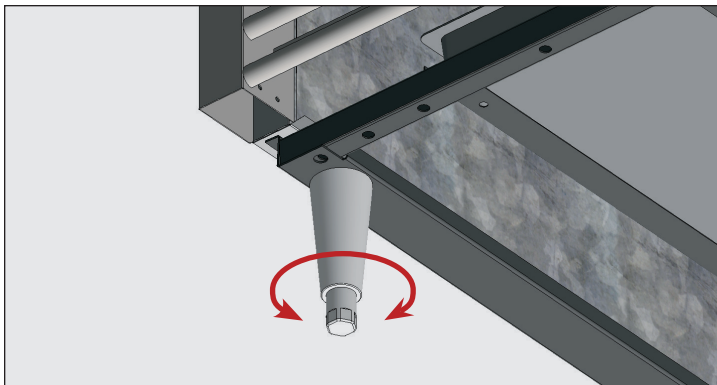

Fig. 6. Turn the bottom stem to level the appliance.

Procedure — Castors

! USER ACTION!

! Install castors with brakes in the front.

1. Access the appliance bottom.
2. If present, remove the leveling screws.
3. Thread the castors into the frame rail or appliance bottom. See figs. 7 and 8.
4. Verify the appliance is level. See "Level the Appliance" (pg. 16).
5. On the low end of the appliance, loosen the castor bolt enough to slide provided castor shims between the castor bearing and the bottom rail of the appliance. See fig. 9.
6. Install the desired number of shims. See fig. 9.
 - If more than one shim is used, be sure shim slots are offset. See fig. 10.
 - **DO NOT** use more than four (4) shims on a castor.
 - Be sure each shim touches the castor stem.
7. Tighten and secure the shims and castors.
8. Verify the appliance is level.
9. If the appliance is not level, repeat the steps 3 – 6 until the appliance is level and supported.

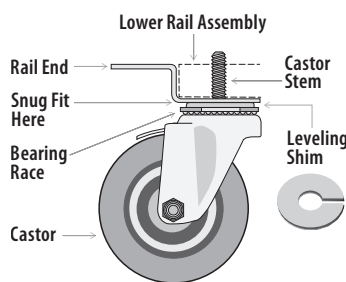

Fig. 7. Castor diagram.

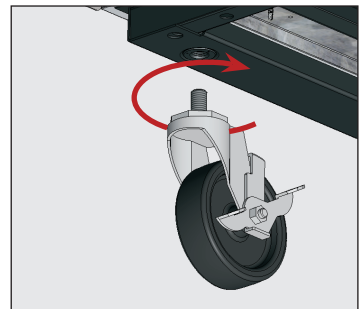

Fig. 8. Screw the castors into the threaded holes.

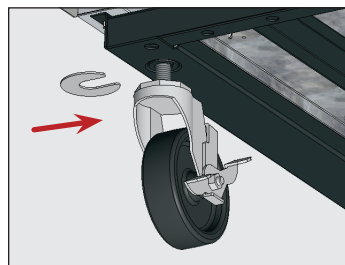

Fig. 9. Insert the castor shim(s). be sure to tighten the castor stem.

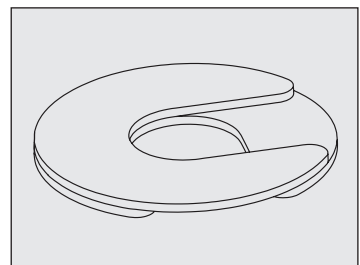

Fig. 10. Install multiple shims with offset slots.

Installation & Setup (cont.)

Level the Appliance

⚠ WARNING!



Tipping hazard! ALWAYS verify center leveling screws fully contact the floor after leveling the appliance.

Proper leveling of your TRUE appliance is critical to operating success (for non-mobile appliances). Leveling impacts effective condensate removal and door operation.

See "Leveling Screw, Leg or Castor Installation" (pg. 14) for level adjustment and shimming information.

Procedure

Position the appliance in its final installation location. Then, level the appliance front-to-back and side-to-side. See fig. 1.

1. Position the level on the inside floor of the appliance near the doors (level parallel to appliance front). Level the appliance.
2. Position the level at the inside rear of the appliance (level parallel to appliance back). Level the appliance.
3. Position the level on the left and right inside floor (level parallel to appliance sides). Level the appliance.

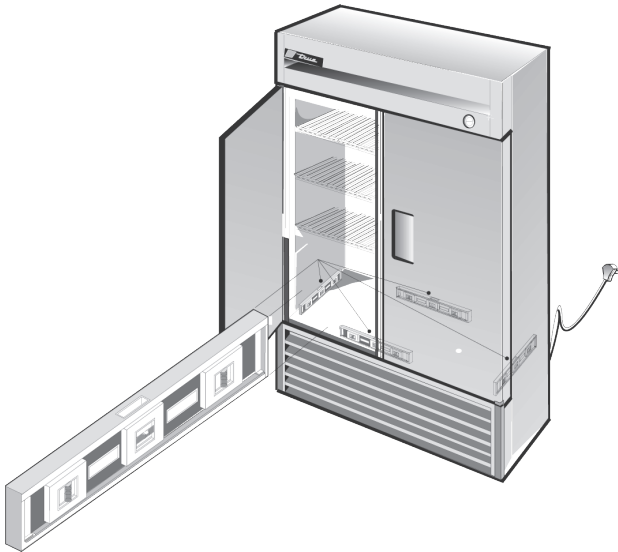

Fig. 1. Measure the level along the perimeter of the interior floor.

Seal the Appliance to the Floor

ⓘ USER ACTION!



Asphalt floors are susceptible to chemicals. TRUE recommends installing a layer of tape between the asphalt and the sealant to protect the floor.

The following procedure describes sealing a non-mobile appliance to the floor for NSF standards. This may not be required for your application.

Procedure

1. Position the appliance in its final installation location. Be sure to leave adequate clearance between the back and sides per "Clearances" (pg. 8) to ensure proper ventilation.
2. Level the appliance front-to-back and side-to-side. See "Level the Appliance" (pg. 16).
3. Draw an outline of the appliance base on the floor.
4. Raise and block the front side of the appliance.
5. Apply a bead of NSF-approved sealant (see list below) to the floor, 1/2" (13 mm) inside the front part of the outline drawn in step 3. The bead of sealant must be heavy enough to seal the entire appliance surface when the appliance is lowered on top of the sealant.
6. Raise and block the rear of the appliance.
7. Apply sealant to the floor on the other three sides, as outlined in step 5.
8. Examine the appliance to ensure that it is sealed to the floor around the entire perimeter.

NSF-Approved Sealants

- 3M #ECU800 Caulk
- 3M #ECU2185 Caulk
- 3M #ECU1055 Bead
- 3M #ECU1202 Bead
- Armstrong Cork – Rubber Caulk
- Products Research Co. #5000 Rubber Caulk
- G.E. Silicone Sealer
- Dow Corning Silicone Sealer

Installation & Setup (cont.)

Battery Backup

! USER ACTION!

!

The battery backup system ships with the power switch toggled to **off**. Turn the battery backup system on during installation. Be sure to check the AA batteries at least once every three (3) months to ensure the battery backup system always has charge.

The appliance has a battery backup to ensure the electronic control can still monitor the appliance temperature and alert during a power outage. The battery backup provides power to the control for a minimum of two (2) hours.

Toggle the Battery Backup

1. Remove the front louver grill. See figs. 1 and 2.
2. On the battery backup, toggle the power switch to **ON**. See fig. 3 and 4.

Test the Battery Backup

Unplug the unit and verify the power failure alarm alerts.

Battery Replacement

The battery backup requires eight (8) AA batteries.

1. Remove the front louver grill. See figs. 1 and 2.
2. Slide the battery backup from its holder.
3. Push the tabs down and slide the battery cover off. See fig. 5.
4. Replace the batteries.

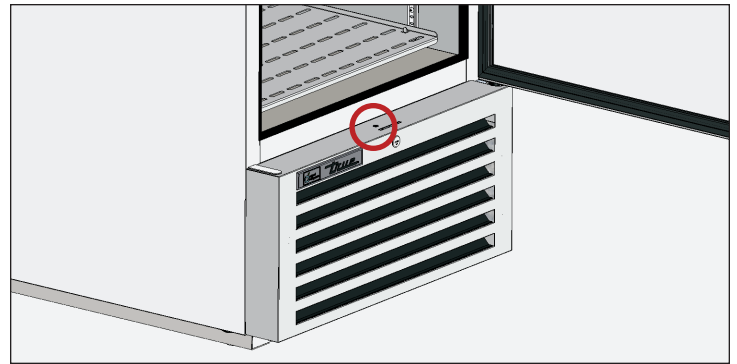

Fig. 1. Upright front louver grill screw location.



Fig. 2. Undercounter front louver grill screw locations.

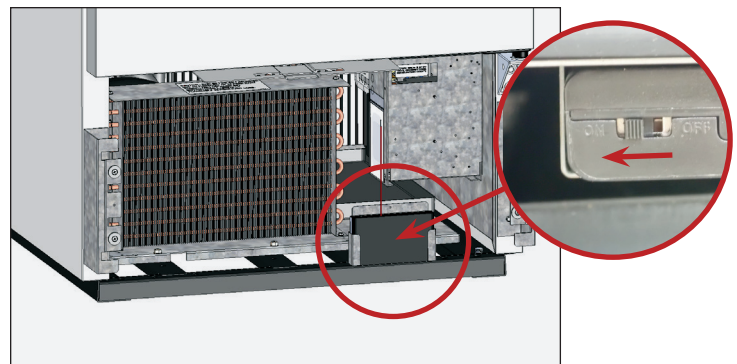

Fig. 3. Upright battery backup location.



Fig. 4. Undercounter battery backup location.



Fig. 5. Slide the battery cover off.

Installation & Setup (cont.)

Glycol Bottle & Temperature Probe

⚠ WARNING!



The appliance owner is responsible for performing a Personal Protective Equipment (PPE) Hazard Assessment and to ensure adequate protection during maintenance and cleaning procedures.



Use appropriate tools, safety equipment, and PPE during installation and servicing.



The glycol bottle and temperature probe assembly help ensure precision in maintaining appliance temperature.

Procedure

1. Unfasten the temperature probe. Do not cut the cable tie. See fig. 1.
2. Locate the glycol bottle kit.
3. Remove the shipping cap from the glycol bottle.
4. On the cap with a hole, loosen the strain relief and insert the probe. Tighten the strain relief. See fig. 2.
5. Install the cap and temperature probe on the glycol bottle.
6. Position the glycol bottle in the desired location for temperature monitoring. See figs. 3 and 4.



Fig. 1. Pull the reusable cable tie tab to release the temperature probe. Undercounter shown.

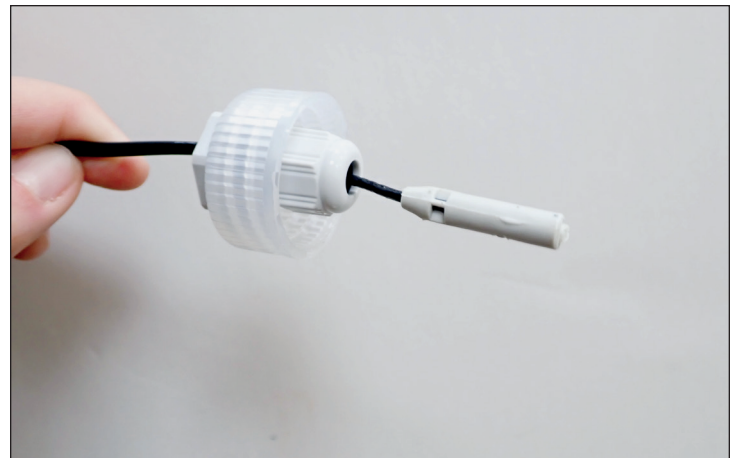

Fig. 2. Black temperature probe through the cap with a hole.



Fig. 3. TRUE recommends installing the glycol bottle assembly at the **top of the right rear shelf standard** as shown. Glycol bottle bracket installed with an existing shelf standard screw. Upright.



Fig. 4. TRUE recommends installing the glycol bottle assembly at the **top of the right rear shelf standard** as shown. Glycol bottle bracket installed with an existing shelf standard screw. Undercounter.

Installation & Setup (cont.)

Shelf Installation

WARNING!

Overloading, incorrectly installing, or improperly loading shelves can cause shelf failure and negatively affect appliance operation, resulting in appliance damage, product damage, or personal injury.

DO NOT use pliers or any crimping tools when installing shelf clips. Altering shelf clips in any way can lead to shelving instability.

Installation Tips

- Install **all** the shelf clips before installing any shelves.
- Start at the bottom shelf and work your way up.
- Always lay the back of each shelf down on the rear clips before the front.

Procedure

1. Hook the shelf clips into the shelf standards. See fig. 1.
2. Push up on the bottom of the clip. See fig. 2.

NOTICE >

 You may need to squeeze or twist the bottom of the shelf clip for proper installation. Position all four shelf clips equal in distance from the floor for flat shelves.
3. Ensure the shelf clip is not loose or able to wiggle out of the shelf standard. See figs. 3 and 4.
4. Place the shelves on the shelf clips. See fig. 5.

NOTICE >

 Be sure all shelf corners are properly seated.

Shelf Adjustment

Shelving is adjustable for customer application. This appliance meets the IEC Shelf Weight Capacity of 47lb/ft² (230kg/m²).

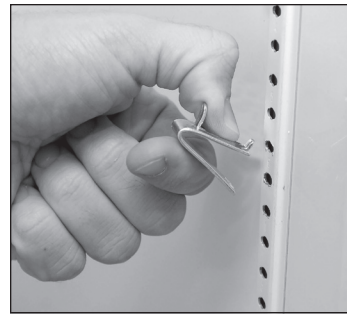

Fig. 1. Installing top tab of shelf clip.



Fig. 2. The bottom tab of the shelf clip will fit tightly.



Fig. 3. You may need to squeeze or twist the bottom of the shelf clip to install.



Fig. 4. Installed shelf clip.

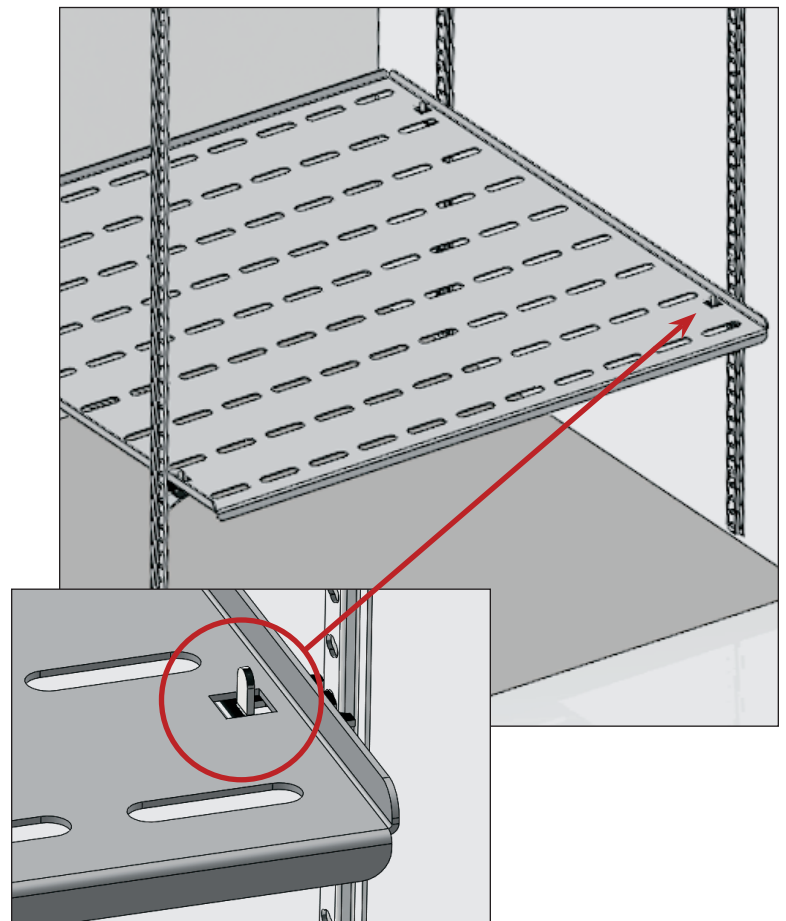

Fig. 5. Fully-seated shelf with shelf clip tabs in the slots.

Installation & Setup (cont.)

Optional Scientific Accessories

Additional Monitoring (not provided by True)

The probe port in the appliance rear allows for installation of an additional monitoring system.

Upright Appliance Location

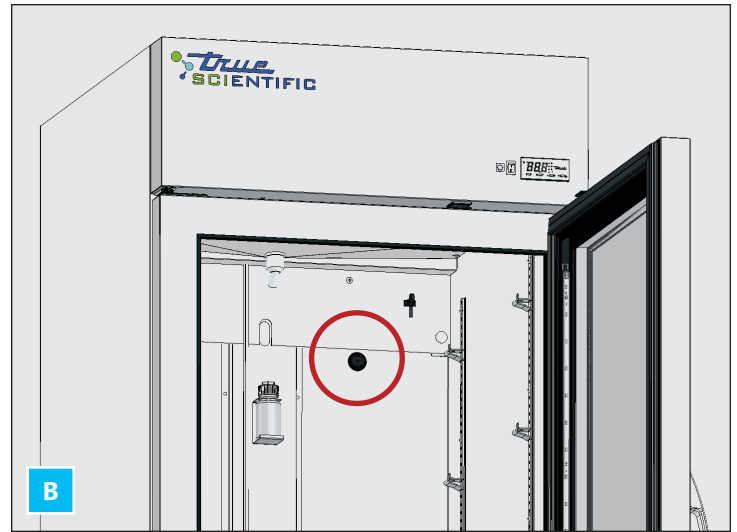
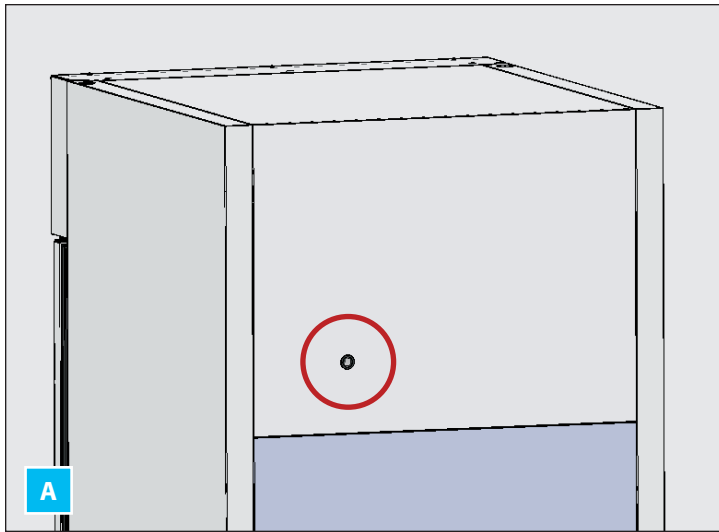

Fig. 1. Upright probe port exterior (A) and interior (B) view.

Procedure

1. With an appropriate cutting tool, cut a small slit through the probe port's exterior and interior sides. See figs. 1 and 2.
2. Feed the additional monitoring system's probe through the probe port into the appliance interior and place the probe within the usable space for storage.

NOTICE > Rubber grommets may come loose during probe installation. Press grommets back into their holes.

Undercounter Appliance Location



Fig. 2. Undercounter probe port exterior (A) and interior (B) view.

Installation & Setup (cont.)

Access Port (Factory Install Only)

Access hole in appliance with cover to run lines, cords or move beakers, etc. See fig. 3.

Chromatography Mast (Factory or Field Install)

300 series stainless steel pole runs vertical inside appliance to clamp beakers or other equipment to. See fig. 4.

- **One-Door:** In center of appliance (requires half shelves).
- **Two and Three-Door:** In between shelves/sections.

Half Shelves (One-Door Models Only; Field Install Only)

Adjustable, heavy duty, PVC coated wire shelves. Includes shelf clips. See fig. 5.

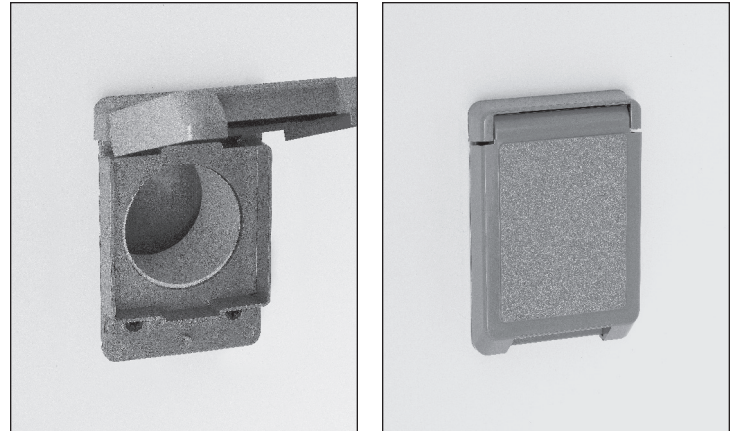

Fig. 3. Access port.



Fig. 4. Chromatography mast and bracket.



Fig. 5. Half shelf with chromatography mast.

Installation & Setup (cont.)

Remote Alarm Contact Location

The remote alarm contacts allow users to connect their own monitoring system to the TSCI appliance. When the appliance enters an alarm status, a relay the wires are connected to will change from an open to closed state.

Upright

The remote alarm contacts are black/gray wires bundled with a reusable cable tie behind the front louver grill. See figs. 1 and 2.

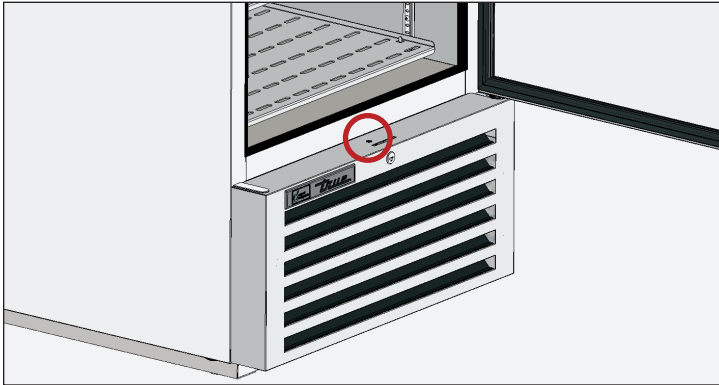

Fig. 1. Front louver grill screw location.

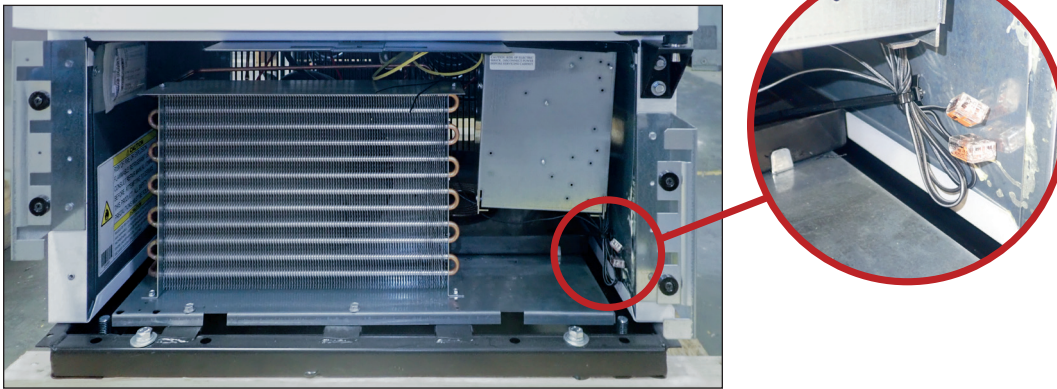

Fig. 1. Remote alarm contact location.

Installation & Setup (cont.)

Undercounter

The remote alarm contacts are black/gray wires bundled with a reusable cable tie behind the rear cover. See figs. 3 and 4.

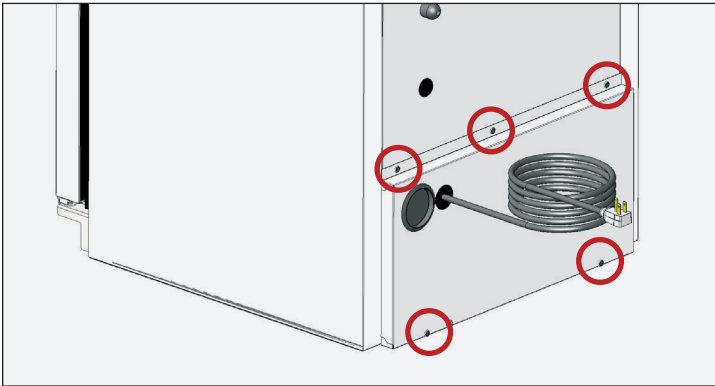





Fig. 3. Rear cover screw location.



Fig. 4. Remote alarm contact location.

Appliance Operation

Appliance Operation

⚠ WARNING	
	<p>The owner is solely responsible for ensuring safe holding temperature levels for all items. Failure to do so may result in unsafe products.</p>  <p>Loss or spoilage of products in your appliance is not covered by warranty. In addition to following recommended installation procedures, follow True's recommended startup procedure (see pg. 24) to verify proper operation.</p>
	<p>Good air flow inside your TRUE appliance is critical. Place product on the provided shelves; never place product directly on the interior floor. Take care to prevent product from pressing against the sides or back wall and coming within 4" (101.6 mm) of the evaporator housing. Refrigerated air off the evaporator coil must circulate throughout the appliance for even product temperatures.</p>

Startup

! USER ACTION!	
	<p>Before loading product, follow True's recommended startup procedure (see pg. 24) to verify proper operation. Remember, our factory warranty DOES NOT cover product loss!</p>

- The compressor is ready to operate when the appliance is purchased. All you need to do is plug in the appliance.
- Excessive tampering with the control could lead to service difficulties. If replacing the temperature control is ever needed, be sure to order the replacement from your TRUE dealer or recommended service agent.
- All covers and access panels must be in place and properly secured before operating this appliance.

Recommended Startup Procedure

1. Power the appliance.
2. Let the appliance run 2-6 hours.
3. Reset the high and low temperature logs (see pg. 35).
4. Check the high and low temperature logs (see pg. 35) after 24 hours of appliance operation to verify the logged temperatures are within your application requirements.

Appliance Operation (cont.)

Temperature Control & Light Switch Location

The light symbol  shows the approximate location of the light switch.



Electronic Temperature Control Display

Inside (behind) rainshield



Electronic Temperature Control Display

Inside countertop.



Appliance Operation (cont.)

Sequence of Operation

When the appliance is plugged in...

1. The lights turn on.
 - a. The display illuminates.
 - b. The interior light will illuminate on Glass Door Models only. Solid Door appliance lights are controlled by the door switch.
2. The evaporator fan starts.
3. After the pre-programmed temperature control delay (up to 4 min), the compressor will start if the control calls for cooling.
 - a. The control or condenser fans are pre-programmed from the factory so at the start of every compressor cycle, the condenser fan(s) will reverse for 30 sec to blow dirt off the condensing coil.
4. The temperature control cycles the compressor on and off as determined by the set point and differential temperatures.
 - a. The temperature control is designed to read and display the glycol bottle temperature. This temperature replicates the average product temperature.
 - b. The set-point is the **adjustable** pre-programmed temperature designed to match the average appliance temperature.
 - c. The differential temperatures are the **non-adjustable** pre-programmed temperatures used to determine when the compressor shuts off and turns on.
 - i. The high differential is added to the set-point and determines when the compressor turns on (cut-in temperature).
 - ii. The low differential is subtracted from the set-point and determines when the compressor turns off (cut-out temperature).

Set Point (SP) = 5°C (41°F)

High Differential (hY0) = 1°C (1.8°F)

SP + hY0 = Cut-In 5°C(41°F) + 1°C (1.8°F) = 6°C (42.8°F)

Low Differential (hY1) = 1°C (1.8°F)

SP - hY1 = Cut-out 5°C (41°F) - 1°C (1.8°F) = 4°C (39.2°F)

5. The temperature control may be pre-programmed to initiate defrost by interval or evaporator temperature.
 - a. The compressor will turn off until a pre-programmed temperature or duration is reached.
6. This control is pre-programmed where an audible alarm will activate when the appliance temperature is above 7°C (45°F) **hi** will appear on the display, indicating a high temperature alarm is active. This alarm is not active for the initial startup and pulldown.

NOTICE > These values may vary by model. See "Adjust Temperature Alarm Ranges" pg. 33 to adjust the temperature alarms for your application.

- a. To silence the audible alarm, press any button on the display.

Electronic Temperature Control

Electronic Temperature Control

L A E CONTROL LEGEND



- Compressor Running
- Evaporator Fan Running
- Appliance in Defrost
- Activation of 2nd Parameter Set
- Alarm
- Info
- Up Arrow
- Down Arrow
- Power/ °F or °C

D I S P L A Y C O D E S

Display	Definition	Display	Definition
<i>def</i>	Defrost in Progress	<i>hi</i>	High Temperature Alarm
<i>off</i>	Controller in Stand-by	<i>Lo</i>	Low Temperature Alarm
<i>do</i>	Door Open Alarm	<i>E1</i>	Probe T1 Failure
<i>t1</i>	Instant Probe Temperature (appliance temperature)	<i>E2</i>	Probe T2 Failure
<i>t2</i>	Instant Probe Temperature (evaporator temperature)	<i>E3</i>	Probe T3 Failure
<i>t3</i>	Instant Probe Temperature (Glycol bottle measured temperature)	<i>th1</i>	Maximum Probe 1 Temperature Recorded
<i>n in</i>	Minutes of the Real Time Clock	<i>tLo</i>	Minimum Probe 1 Temperature Recorded
<i>hr5</i>	Hours of the Real Time Clock	<i>Loc</i>	Keypad State Lock

Electronic Temperature Control (cont.)

L A E CONTROL LEGEND



- Compressor Running
- Evaporator Fan Running
- Appliance in Defrost
- Activation of 2nd Parameter Set
- Alarm
- Info
- Up Arrow
- Down Arrow
- Power/°F or °C

Lock / Unlock the Control

NOTICE > The control is locked by default.

1. Press info to show t1.



2. Press the down arrow to show **Loc**.



3. Press and hold info to show the current lock status. DO NOT RELEASE THE BUTTON!



YES = Locked

no = Unlocked

4. Press the arrows to change the lock setting.

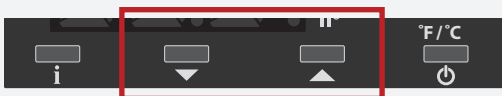

5. Release all buttons and wait for the control to display the appliance temperature.

NOTICE > Control will remain locked/unlocked until manually changed.

Turn Off / On the Control

NOTICE > May need to unlock the control (pg. 29).

⚠ WARNING!

Risk of electric shock or burn! Powering off an electronic does not remove power from all components. Unplug the appliance or turn off the power supply before installation or servicing.

Turning off the control deactivates the refrigeration system and all electronic components connected to the control. The lights will remain powered.

Turn Off

Press and hold power until the display shows **oFF**.



Turn On









Press and hold power until the display shows **on**.



Electronic Temperature Control (cont.)

LA E CONTROL LEGEND



-  Compressor Running
-  Evaporator Fan Running
-  Appliance in Defrost
-  Activation of 2nd Parameter Set
-  Alarm
-  Info
-  Down Arrow
-  Up Arrow
-  Power/°F or °C



Change the Set Point

NOTICE > May need to unlock the control (pg. 29).

Changing the set point adjusts the appliance temperature to keep optimal product temperature.

1. Press and hold info  until the display shows the current set point. **DO NOT RELEASE THE BUTTON!**



2. While holding info, press the up  or down  arrows to adjust the setting.



3. Release all buttons and wait for the control to display the current appliance temperature.

Initiate Manual Defrost

NOTICE > May need to unlock the control (pg. 29).

A manual defrost clears accumulated frost and ice from the evaporator coil. The defrost will only terminate when a specific preset temperature or duration has been met.

Press the down arrow  until the display shows **deF**.





Change Defrost Intervals

The defrost interval is the duration between defrost cycles.

NOTICE > The defrost interval **can only be changed** if the defrost mode parameter **dFm** is set for **tim** or **Fro**.

NOTICE > May need to unlock the control (pg. 29).

1. Press and hold both info  and power  until the display shows **MdL**





2. Press the up arrow  until the display shows **dFt**.



3. Press and hold info until the display shows the defrost interval time. **DO NOT RELEASE THE BUTTON!**



4. While holding info, press the up  or down  arrows to adjust the setting.



5. Release all buttons and wait for the control to display the current appliance temperature.

Electronic Temperature Control (cont.)

L A E CONTROL LEGEND



- Compressor Running
- Evaporator Fan Running
- Appliance in Defrost
- Activation of 2nd Parameter Set
- Alarm
- Info
- Up Arrow
- Down Arrow
- Power/°F or °C

Change Display Readout

NOTICE ▶ May need to unlock the control (pg. 29).

The display can show the temperature in either Fahrenheit or Celsius. The display shows Celsius at 0.1 precision by default.

With the display unlocked, press power to cycle through the display readout options.

- °F Fahrenheit (no decimal)
- 1°C Celsius (0.1 precision; default)
- 2°C Celsius (no decimal)

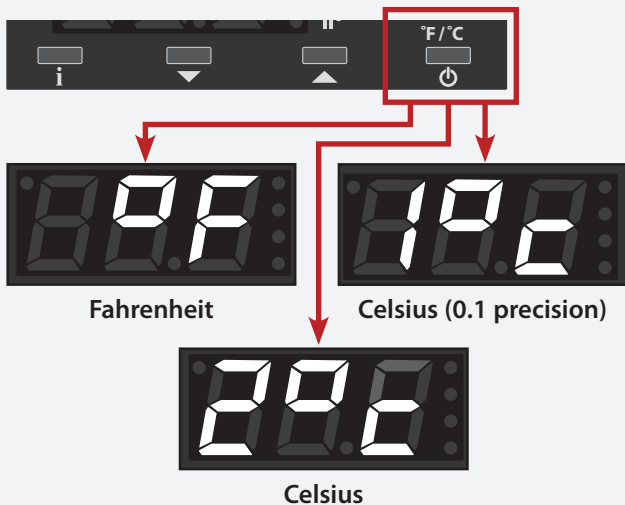

Display Probe Temperatures

The display shows the temperature probe readings in different locations of the appliance.

- **T1:** Appliance temperature
- **T2:** Evaporator temperature
- **T3:** Glycol bottle temperature (default display temperature)

1. Press info to show **t1**.



2. Press and hold info to show the current **t1** probe temperature.



3. Release info to show **t2**.











4. Press and hold info to show the current **t2** probe temperature.



Electronic Temperature Control (cont.)

LA E CONTROL LEGEND



-  Compressor Running
-  Evaporator Fan Running
-  Appliance in Defrost
-  Activation of 2nd Parameter Set
-  Alarm
-  Info
-  Down Arrow
-  Up Arrow
-  Power/°F or °C

Display Probe Temperatures (cont.)

1. Release info  to show **t3**.



2. Press and hold info to show the current **t3** probe temperature.



3. Release all buttons and wait for the control to display the current appliance temperature

Temperature Alarms

Changing the set point adjusts the appliance temperature to keep optimal product temperature.

- The alarm values shown may vary by model. Please see “Adjust Temperature Alarm Ranges” (pg. 30) to adjust the temperature alarms for your application.
- During alarms, the display flashes between the alarm and the current temperature.
- The high temperature alarm has a delay for the unit’s initial startup.
- If an alarm has been silenced but the reason for the alarm persists, the control will sound a 20 sec alert every 60 min until the alarm condition has been resolved as described below.

High Temperature Alarm



An audio/visual alarm that warns when the internal appliance temperature rises above accepted parameters.

Why it Occurs

If the internal appliance temperature reads $\geq 7^{\circ}\text{C}$ (45°F) the control emits a series of beeps and the display flashes **hi**.

Silencing the Alarm

Press **ANY** button to silence the alarm. The display will continue to flash **hi** until the internal appliance temperature reads $< 7^{\circ}\text{C}$ (45°F).

Low Temperature Alarm



An audio/visual alarm that warns when the internal appliance temperature drops below accepted parameters.

Why it Occurs

If the internal appliance temperature reads $\leq 2^{\circ}\text{C}$ (36°F) the control emits a series of beeps and the display flashes **Lo**.

Silencing the Alarm

Press **ANY** button to silence the alarm. The display will continue to flash **Lo** until the internal appliance temperature reads $> 2^{\circ}\text{C}$ (36°F).

Electronic Temperature Control (cont.)

LAE CONTROL LEGEND



- Compressor Running
- Evaporator Fan Running
- Appliance in Defrost
- Activation of 2nd Parameter Set
- Alarm
- Info
- Down Arrow
- Up Arrow
- Power/°F or °C

Door Open Alarm



An audio/visual alarm that warns when the door remains open longer than accepted parameters.

Why it Occurs

If the door remains open for ≥ 60 seconds, the control emits a series of beeps and the display flashes **do**.

Silencing the Alarm

Shut the door to stop the alarm. Alternately, press **ANY** button to silence the alarm. The display will continue to flash **do** until the door closes.

Adjust Temperature Alarm Ranges

NOTICE > May need to unlock the control (pg. 29).

The temperature ranges are adjustable for different customer applications. Please note the values shown are for Fahrenheit.

Step 1: Change Alarm Mode (AtM)

1. Press and hold both info and power until the display shows **MdL**



2. While the display shows **MdL**, press info until the display shows **AtM**.



3. While the display shows **AtM** press and hold info to show the current setting. **DO NOT RELEASE THE BUTTON!**



4. While holding info, press the down arrow until the display shows **AbS** (alarm is an absolute number).











5. Release **ALL** buttons to show **ALA**. Proceed to **Step 2**.

Electronic Temperature Control (cont.)

LA E CONTROL LEGEND





-  Compressor Running
-  Evaporator Fan Running
-  Appliance in Defrost
-  Activation of 2nd Parameter Set
-  Alarm
-  Info
-  Down Arrow
-  Up Arrow
-  Power/ °F or °C

Step 2: Change Low Alarm Setting (ALA)

1. While the display shows **ALA**, press and hold info  to show the current setting. **DO NOT RELEASE THE BUTTON!**



2. While holding info , press the up  or down  arrows to change the current setting.

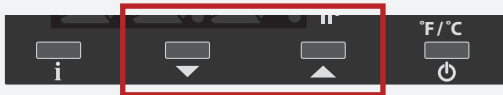



3. Release **ALL** buttons to show **AhA**. Proceed to **Step 3**.

Step 3: Change High Alarm Setting (AhA)

1. While the display shows **AhA**, press and hold info  to show the current setting. **DO NOT RELEASE THE BUTTON!**



2. While holding info , press the up  or down  arrows to change the current setting.

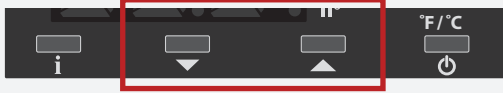

3. Release **ALL** buttons. Proceed to **Step 4**.



Step 4: Change Temperature Alarm Delay (Atd)

1. Press info  until the display shows **Atd**



2. While the display shows **Atd** press and hold info to show the current setting. **DO NOT RELEASE THE BUTTON!**



3. While holding info, press the up  or down  arrows to change the current setting.

NOTICE > Alarm delay is measured in minutes.











4. Release **ALL** buttons and wait for the control to display the current appliance temperature.

Electronic Temperature Control (cont.)

L A E CONTROL LEGEND



-  Compressor Running
-  Evaporator Fan Running
-  Appliance in Defrost
-  Activation of 2nd Parameter Set
-  Alarm
-  Info
-  Down Arrow
-  Up Arrow
-  Power/°F or °C

High (thi) & Low (tLo) Temperature Log

! USER ACTION!

- The control typically records the **thi** during the initial startup. Reset the **thi** log after 24 hours of operation.
- Reset the log after a high or low temperature alarm.

The High/Low Temperature Log allows user to see maximum and minimum temperatures recorded since the log was last reset.

View the Log

- Tap info  until the display shows either **thi** or **tLo**.



- Press and hold info until the display shows the logged maximum or minimum temperature.



Reset the Log

- Tap info  until the display shows either **thi** or **tLo**.



- Press and hold info until the display shows the logged temperature. **DO NOT RELEASE THE BUTTON!**

- Tap power , to set the log to the current internal appliance temperature.



Maintenance & Servicing

Maintenance & Servicing

⚠ WARNING!	
	<ul style="list-style-type: none"> • Only qualified technicians should install and service the appliance. For assistance finding a qualified technician, please visit our Service Company Locator at truemfg.com/support/service-locator. • Turn off and lockout all utilities (gas, electric, water) according to approved practices during maintenance or servicing.
 	<p>The appliance owner is responsible for performing a Personal Protective Equipment (PPE) Hazard Assessment and ensuring adequate protection during maintenance and cleaning procedures.</p> <p>Use appropriate tools, safety equipment, and PPE during installation and servicing.</p>
	<p>Sharp Edges!</p> <ul style="list-style-type: none"> • Take care when moving, installing, cleaning, servicing, and maintaining the ice machine to avoid cuts. Be sure to take care when reaching under the ice machine or handling metal components. • Stay clear of pinch point areas, such as the space between appliance doors and surrounding cabinetry. Take care closing doors with children nearby.

⚠ WARNING!	
	<p>Risk of electric shock or burn!</p> <ul style="list-style-type: none"> • Powering off an electronic control or setting temperature controls to the 0 (off) position DOES NOT remove power from all components. Unplug the appliance or turn off the power supply before installation or servicing. • DO NOT clean appliance with a pressure washer or hose.
	<p>Flammable refrigerant/insulation used! Have a licensed service provider service your appliance to minimize the risk of possible ignition due to incorrect parts or improper service and to ensure the operator's health and safety.</p>
	<p>Crush or cut hazard! Keep clear when uncrating, installing, moving, or servicing the appliance.</p>
	<p>Slippery Surfaces! Moisture from improper drainage can create slippery surfaces near the appliance. It is your duty to immediately warn your customers of, and dry, the slippery surface. All wet floor areas must be marked with a wet floor sign.</p>

Maintenance & Servicing (cont.)

ⓘ USER ACTION!

- For additional maintenance instruction, please visit the media center at truemfg.com.
- Any appliance adjustments are to be made **AFTER** the appliance has been verified level and properly supported.

ⓘ NOTICE!

The appliance owner is responsible for maintaining the appliance as described in the installation manual. Routine care and maintenance procedures are not covered by TRUE's warranty.

Component Replacement

- Replace components with original equipment manufacturer (OEM) components such as those shown in fig. 1. OEM parts minimize the risk of possible ignition due to incorrect parts. Use of non-OEM components may void TRUE's warranty.
- Have a licensed service provider service your appliance to minimize the risk of possible ignition due to incorrect parts or improper service and to ensure the operator's health and safety.



Fig. 1. Example of OEM parts.

Maintenance & Servicing (cont.)

Recommended Maintenance

See recommended maintenance tasks and frequencies below. Some tasks may be required more frequently based on your installation.

Maintenance Tasks	Monthly	Quarterly	Annually
Verify the appliance maintains product temperature.	X	X	X
Verify glycol bottle is filled and probe is submersed		X	X
Inspect power cord for damage; if damaged, replace immediately.	X	X	X
Verify the power cord is fully plugged into the wall receptacle			X
Inspect the overall condition of the appliance and its components (such as castors, doors, and hinges).	X	X	X
Verify operation of all moving parts (such as fan motors, doors and door cords).			X
Check battery backup system.		X	X
Check physical condition of all gaskets; verify gaskets seal correctly.		X	X
Inspect any lamps, lamp holder connections, LED modules, and LED module connections.	X	X	X
Check all condenser coils (fronts and backs) for dust and debris; if present, clear the debris.	X	X	X
Check physical condition of all condenser coils and evaporator coils; straighten coil fins as needed.		X	X
Check all evaporator coils for dust and debris; if present, clear the debris.		X	X
Verify the drain line is clear of debris.		X	X

Maintenance & Servicing (cont.)

Condenser Coil Cleaning (Upright)

⚠ WARNING!



The appliance owner is responsible for performing a Personal Protective Equipment (PPE) Hazard Assessment and ensuring adequate protection during maintenance and cleaning procedures.



Use appropriate tools, safety equipment, and PPE during installation and servicing.



Risk of electric shock or burn!

- Unplug the appliance or turn off the power supply before installation or servicing.
- **DO NOT** clean appliance with a pressure washer or hose.



Sharp edges! Coil fins are sharp and metal components can have sharp edges. Take care when moving, installing, cleaning, servicing, and maintaining the appliance to avoid cuts.



Risk of eye injury! Airborne dust and debris can cause eye injury. Eye protection recommended.

Required Tools

Required tools include (but may not be limited to) the following:

- Eye protection
- Gloves
- Phillips screwdriver or bit driver
- Stiff bristle brush
- Tank of compressed air
- Vacuum cleaner
- Flashlight
- Drill (optional)

Procedure

1. Disconnect power to unit.
2. Remove the front louver grill. See fig. 1.
3. With a stiff bristle brush, carefully clean accumulated dirt from the front condenser coil fins. See fig. 2.

4. With dirt removed from the surface of the coil, use a flashlight to verify that you can see through the coil and observe the condenser fan blade spinning. See fig. 3.

- If the view is clear, carefully vacuum any dirt around or behind the condensing unit area. Then reinstall the front louver grill, restore power, and verify operation.
- If the view is still blocked with dirt, proceed to the next step.

5. Gently blow compressed air or CO₂ through the coil until it is clean.
6. Carefully vacuum any dirt around and behind the condensing unit area.
7. Reinstall the rear cover, restore power to the unit, and verify operation.

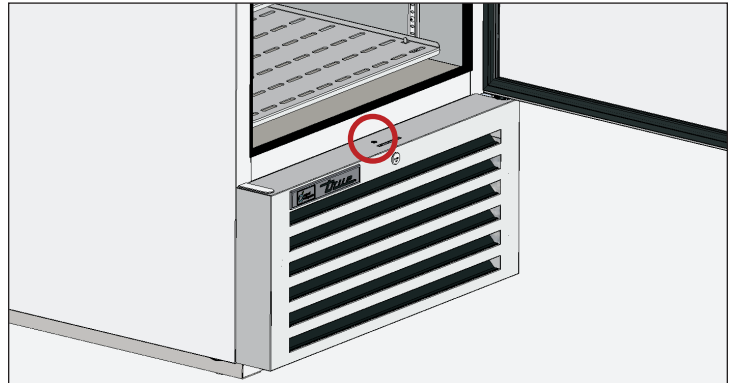

Fig. 1. Front louver grill screw location.

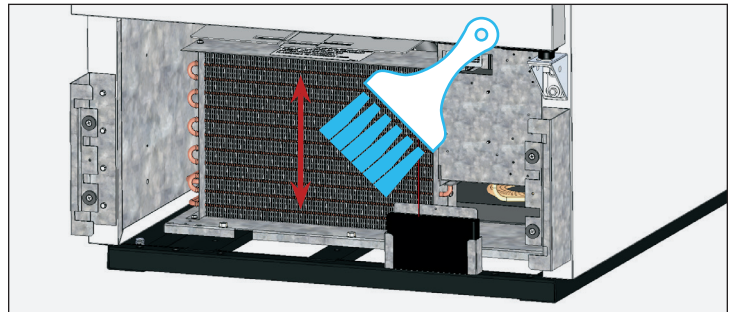

Fig. 2. Never brush across coil fins.

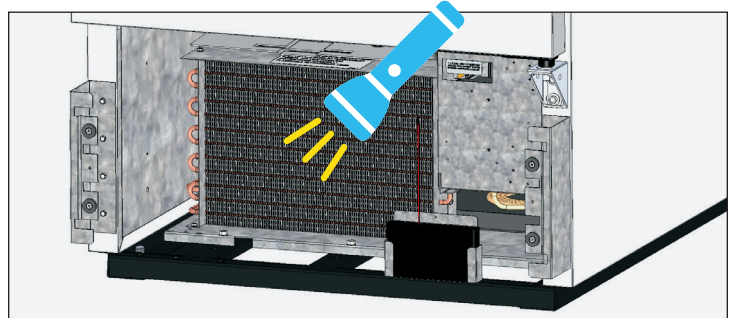







Fig. 3. Verify all blockages have been removed.

Maintenance & Servicing (cont.)

Condenser Coil Cleaning (Undercounter)

⚠ WARNING!	
  	<p>The appliance owner is responsible for performing a Personal Protective Equipment (PPE) Hazard Assessment and ensuring adequate protection during maintenance and cleaning procedures.</p> <p>Use appropriate tools, safety equipment, and PPE during installation and servicing.</p>
	<p>Risk of electric shock or burn!</p> <ul style="list-style-type: none"> Unplug the appliance or turn off the power supply before installation or servicing. DO NOT clean appliance with a pressure washer or hose.
	<p>Sharp edges! Coil fins are sharp and metal components can have sharp edges. Take care when moving, installing, cleaning, servicing, and maintaining the appliance to avoid cuts.</p>
	<p>Risk of eye injury! Airborne dust and debris can cause eye injury. Eye protection recommended.</p>

- With dirt removed from the surface of the coil, use a flashlight to verify that you can see through the coil and observe the condenser fan blade spinning. See fig. 3.
 - If the view is clear, carefully vacuum any dirt around or behind the condensing unit area. Then reinstall the front louver grill, restore power, and verify operation.
 - If the view is still blocked with dirt, proceed to the next step.
- Gently blow compressed air or CO₂ through the coil until it is clean.
- Carefully vacuum any dirt around and behind the condensing unit area.
- Reinstall the rear cover, restore power to the unit, and verify operation.

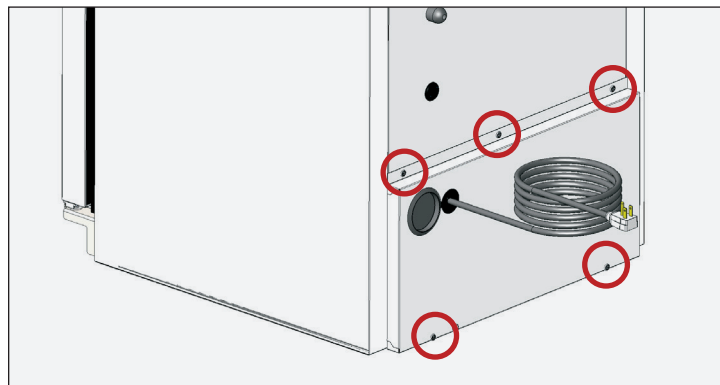

Fig. 1. Rear cover screw locations.

Required Tools

Required tools include (but may not be limited to) the following:

- Eye protection
- Gloves
- Phillips screwdriver or bit driver
- 1/4 Hex Head Driver
- Stiff bristle brush
- Tank of compressed air
- Vacuum cleaner
- Flashlight
- Drill (optional)

Procedure

- Disconnect power to unit.
- Remove the front louver grill. See fig. 1.
- With a stiff bristle brush, carefully clean accumulated dirt from the front condenser coil fins. See fig. 2.

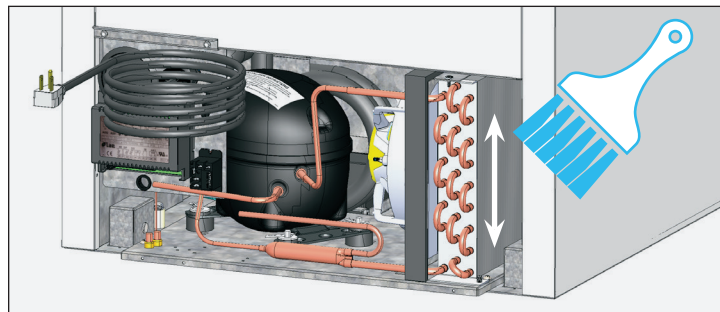

Fig. 2. Never brush across coil fins.

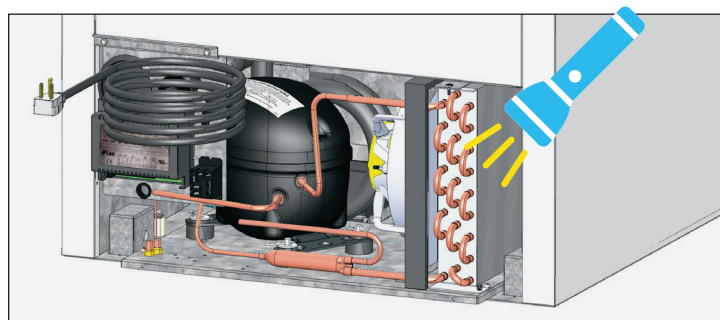

Fig. 3. Verify all blockages have been removed.







Maintenance & Servicing (cont.)

Additional Information

If you have any questions, please contact your local TRUE Manufacturing Service Department. See the front cover for locations and contact information.

- **DO NOT** place any filter material in front of the condensing coil.

General Surface Care & Cleaning

⚠ WARNING!	
 	<p>Risk of electrical shock or fire!</p> <p>DO NOT clean appliance with a pressure washer or hose.</p>
	<p>Slippery Surfaces! Moisture from improper drainage can create slippery surfaces near the appliance. It is your duty to immediately warn your customers of, and dry, the slippery surface. All wet floor areas must be marked with a wet floor sign.</p>
  	<p>The appliance owner is responsible for performing a Personal Protective Equipment (PPE) Hazard Assessment and to ensure adequate protection during maintenance and cleaning procedures.</p> <p>Use appropriate tools, safety equipment, and PPE during installation and servicing.</p>

Gaskets

- Clean gaskets with warm soapy water.
- **DO NOT** use sharp tools or knives to scrape a gasket.
- Avoid full-strength cleaning products.

Interior

- Clean interior surfaces with a mild solution of baking soda and water to help reduce odor; **DO NOT** use harsh or abrasive cleaners.
- For plastic or powder-coated parts, use warm soapy water to clean **DO NOT** use stainless steel cleaners or similar solvents.

Exterior

- For plastic or powder-coated parts, use warm soapy water to clean **DO NOT** use stainless steel cleaners or similar solvents.
- **DO NOT** clean stainless steel with steel wool or abrasive products. **DO NOT** use detergents or degreasers with chlorides or phosphates. See model-specific manual for more information.

Maintenance & Servicing (cont.)

Stainless Steel Care & Cleaning

! USER ACTION



DO NOT use any steel wool, abrasive, or chlorine-based products to clean stainless steel surfaces.

Stainless Steel Opponents

There are three basic things which can break down your stainless steel's passivity layer and allow corrosion to form.

- Scratches from wire brushes, scrapers, steel pads, and other items that can be abrasive to stainless steel's surface.
- Deposits left on your stainless steel can leave spots. You may have hard or soft water depending on what part of the country you live in. Hard water can leave spots. Hard water that is heated can leave deposits if left to sit too long. These deposits can cause the passive layer to break down and rust your stainless steel. All deposits should be removed as soon as possible.
- Chlorides which are present in table salt and water, as well as in household and industrial cleaners. These are the worst type of chlorides to use on stainless steel.

Stainless Steel Cleaning and Restoration

Stainless steel cleaners must be free of phosphates, chlorine, chloride, and ammonia.

True offers environmentally-friendly cleaner and polish through our True Store at <https://store.trueresidential.com/products/stainless-steel-clean-polish-kit>

Custom Painted Appliance and Hardware

For painted doors and other surfaces, use a mild solution of soap and water with a soft microfiber cloth.

Maintenance & Servicing (cont.)

8 Tips to Help Prevent Rust on Stainless Steel

Maintain the Cleanliness of Your Equipment

Avoid build-up of hard stains by cleaning frequently. Use cleaners at the recommended strength (alkaline chlorinated or non-chloride).

Use the Correct Cleaning Tools

Use non-abrasive tools when cleaning your stainless steel products. The stainless steel's passive layer will not be harmed by soft cloths and plastic scouring pads.

Clean Along Polishing Lines

Polishing lines ("grain") are visible on some stainless steels. Always scrub parallel to polishing lines when visible. Use a plastic scouring pad or soft cloth when you cannot see the grain.

Use Alkaline, Alkaline-Chlorinated or Non-Chloride Cleaners

While many traditional cleaners are loaded with chlorides, the industry is providing an ever increasing choice of non-chloride cleaners. If you are not sure of your cleaner's chloride content, contact your cleaner supplier. If they tell you that your present cleaner contains chlorides, ask if they have an alternative. Avoid cleaners containing quaternary salts, as they can attack stainless steel, causing pitting and rusting.

Rinse

When using chlorinated cleaners, you must rinse and wipe dry immediately. It is better to wipe standing cleaning agents and water as soon as possible. Allow the stainless steel equipment to air dry. Oxygen helps maintain the passivity film on stainless steel.

Never Use Hydrochloric Acid (Muriatic Acid) on Stainless Steel

Even diluted, hydrochloric acid can cause corrosion, pitting and stress corrosion cracking of stainless steel.

Water Treatment

To reduce deposits, soften hard water when possible. Installation of certain filters can remove corrosive and distasteful elements. Salts in a properly maintained water softener can also be to your advantage. Contact a treatment specialist if you are not sure of the proper water treatment.



Regularly Restore & Passivate Stainless Steel

Stainless steel gets its stainless properties from the protective chromium oxides on its surface. If these oxides are removed by scouring, or by reaction with harmful chemicals, then the iron in the steel is exposed and can begin to oxidize, or rust. Passivation is a chemical process that removes free iron and other contaminants from the surface of stainless steel, allowing the protective chromium oxides to re-form.

Maintenance & Servicing (cont.)

Lock & Cam Replacement

⚠ WARNING!

	<p>The appliance owner is responsible for performing a Personal Protective Equipment (PPE) Hazard Assessment and ensuring adequate protection during maintenance and cleaning procedures.</p> <p>Use appropriate tools, safety equipment, and PPE during installation and servicing.</p>
	<p>Sharp edges! Take care when moving, installing, cleaning, servicing, and maintaining the appliance to avoid cuts. Be sure to take care when reaching under the appliance or handling metal components.</p> <p>Keep fingers out of pinch point areas, such as the space between appliance doors, and surrounding cabinetry. Take care closing doors with children nearby.</p>

NOTICE > The door must be open prior to proceeding.

Removing Components

1. Insert the master key (included with replacement lock kit) into the lock cylinder. See fig. 1.
2. Turn the key and raise the cam.
3. While holding the cam, pull the key and lock cylinder from the lock barrel. See fig. 2.
4. Slide the lock cam out of the lock barrel. See fig. 2.

Installing Components

1. Slide the lock cam into the lock barrel.
2. Insert the master key into the lock cylinder.
3. Push the lock cylinder with master key into the lock barrel.

NOTICE > Ensure the lock cylinder pin aligns with the cam bar notch. See fig. 3.

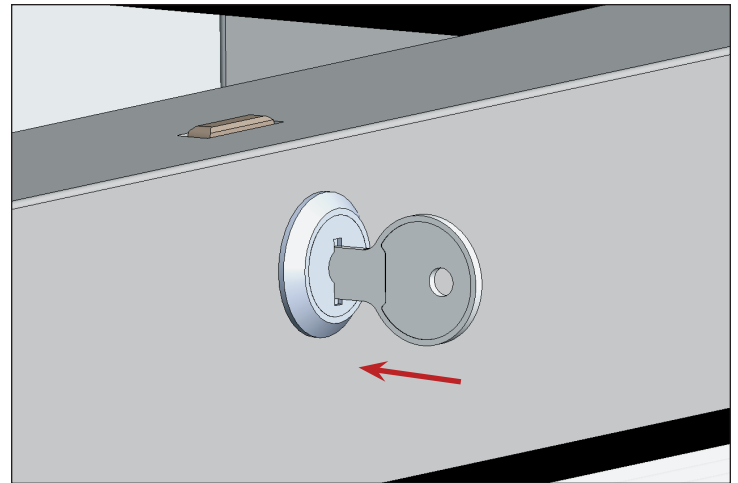

Fig. 1. Insert the master key into the lock cylinder.

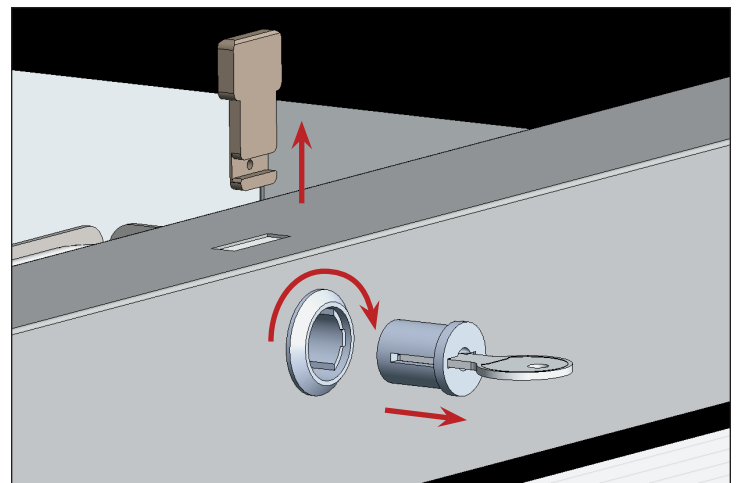

Fig. 2. Remove the cam and lock cylinder

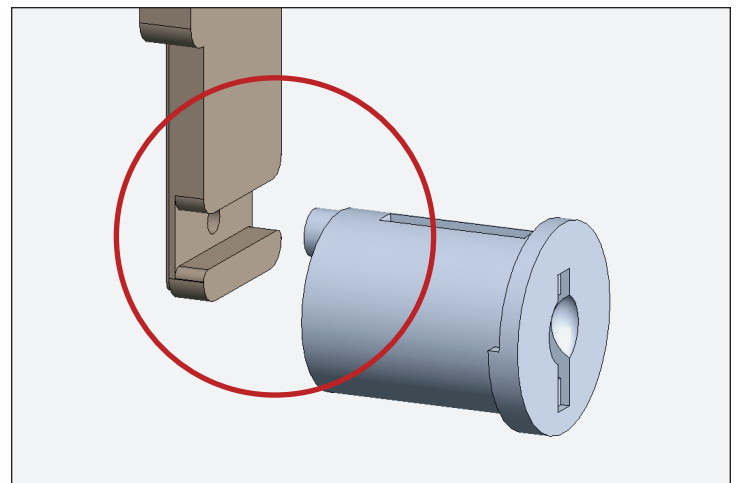

Fig. 3. Cam notch and lock cylinder pin

Warranty Information (USA & Canada Only)

THREE-YEAR LABOR WARRANTY

TRUE warrants to the original purchaser of every new TRUE product, all parts thereof, to be free from defects in material or workmanship, under normal and proper use and maintenance service as specified by TRUE and upon proper installation and start-up in accordance with the instructional information supplied with each TRUE unit. TRUE's labor coverage obligation under this warranty is limited to a period of three (3) years from the date of the original installation. Any warranty coverage is dependent on the purchase date of the unit being within 39 months of the original ship date from TRUE. The labor warranty shall include standard straight time labor charges only and reasonable travel time, as determined by TRUE. Warranty does not cover issues caused by improper installation or lack of basic preventative maintenance.

FIVE-YEAR PART WARRANTY

Any part covered under this warranty that is determined by TRUE to have been defective within this time frame, is limited to the repair or replacement of defective parts or assemblies. Warranty does not cover standard wear parts which include door gaskets, incandescent bulbs, or fluorescent bulbs.

SEVEN-YEAR COMPRESSOR WARRANTY

In addition to the warranty stated above, TRUE warrants its hermetically and semi-hermetically sealed compressor to be free from defects in both material and workmanship under normal and proper use and maintenance service for a period of seven (7) years total for compressor defects, part only.

Compressors determined by TRUE to have been defective within this time period will, at TRUE's option, be either repaired or replaced with a compressor or compressor parts of similar design and capacity.

The compressor component warranty applies only to hermetically and semi-hermetically sealed parts of the compressor and does not apply to any other parts or components, including, but not limited to: cabinet, paint finish, temperature control, refrigerant, metering device, driers, motor starting equipment, fan assembly or any other electrical component, etcetera.

The seven (7) year compressor warranty detailed above will be voided if the following procedure is not carefully adhered to:

1. This system contains R404A, R134A, or R290 refrigerant and polyol ester lubricant. The polyol ester lubricant has rapid moisture absorbing qualities. If long exposure to the ambient conditions occur, the lubricant must be removed and replaced with new. For oil amounts and specifications please call TRUE technical service department (855-372-1368). Failure to comply with recommended lubricant specification will void the compressor warranty.
2. Drier replacement is very important and must be changed when a system is opened for servicing. An OEM exact replacement should be used. The new drier must also be the same capacity as the drier being replaced.
3. Micron level vacuums must be achieved to ensure low moisture levels in the system. 500 microns or lower must be obtained.
4. All True Good Refrigeration Practices must be followed. Visit www.TrueMfg.com to view Good Refrigeration Practices.

WARRANTY CLAIMS

All claims for labor or parts must be made directly through TRUE. All claims should include: model number of the unit, the serial number of the unit, proof of purchase, date of installation, and all pertinent information supporting the existence of the alleged defect.

In case of warranty compressor, a picture of the compressor model tag must be returned to TRUE along with above listed information to CompressorTags@truemfg.com. For warranty claim information, visit www.TrueMfg.com. Claims can be emailed to WarrantyClaims@truemfg.com. Failure to notify TRUE within three (3) months of the defect giving rise to the breach will bar any remedy under warranty.

True reserves the right to request any failed part covered under warranty to be returned.

WHAT IS NOT COVERED BY THIS WARRANTY

TRUE's sole obligation under this warranty is limited to either repair or replacement of parts, at TRUE's option and subject to the additional limitations below. This warranty neither assumes nor authorizes any person to assume obligations other than those expressly covered by this warranty.

NO CONSEQUENTIAL DAMAGES. True is not responsible for economic loss; profit loss; or special, indirect or consequential damages, including without limitation, loss or damage arising from loss of product, whether or not on account of failure of refrigeration.

WARRANTY IS NOT TRANSFERABLE. This warranty is not assignable and applies only in favor of the original purchaser/user to whom delivered. ANY SUCH ASSIGNMENT OR TRANSFER SHALL VOID ALL WARRANTIES, EXPRESS OR IMPLIED.

IMPROPER USAGE/INSTALLATION. TRUE assumes no liability for parts or labor coverage for component failure or other damages resulting from improper usage or installation.

RELOCATION FOR REPAIR. True is not responsible for the cost to move the TRUE unit or any other fixture or piece of equipment for any reason from its position of operation on the user's premises to make a warranty repair.

NON-OEM PARTS. OEM parts will be provided under this warranty free of charge to the end-user. True is not responsible for defects or damage caused by parts not approved by TRUE. Warranty will be voided for any damage caused by a non-OEM part.

ALTERATION, NEGLIGENCE, ABUSE, MISUSE, ACCIDENT, DAMAGE DURING TRANSIT OR INSTALLATION, FIRE, FLOOD, ACTS OF GOD. TRUE is not responsible for the repair or replacement of any parts that TRUE determines have been subjected after the date of manufacture to alteration, neglect, abuse, misuse, accident, or damage during transit or installation, fire, flood, or act of God. Warranty does not cover damage resulting from use of equipment not manufactured by True.

IMPROPER ELECTRICAL CONNECTIONS FOR ANY REASON. TRUE is not responsible for the repair or replacement of failed or damaged components resulting from incorrect supply voltage, the use of extension cords, low voltage, or unstable supply voltage.

NO IMPLIED WARRANTY OF MERCHANTABILITY OR FITNESS FOR A PARTICULAR PURPOSE: THERE ARE NO OTHER WARRANTIES, EXPRESSED, IMPLIED OR STATUTORY, EXCEPT AS SET FORTH IN THIS WARRANTY STATEMENT. THESE WARRANTIES ARE EXCLUSIVE AND IN LIEU OF ALL OTHER WARRANTIES, EXPRESS OR IMPLIED, INCLUDING IMPLIED WARRANTY AND MERCHANTABILITY OR FITNESS FOR A PARTICULAR PURPOSE. THERE ARE NO WARRANTIES WHICH EXTEND BEYOND THE DESCRIPTION ON THE FACE HEREOF.

UNITS COVERED BY THIS WARRANTY

This warranty only applies to US & Canada True Scientific units that have a model starting with "TSCI" shipped from True's manufacturing facilities after January 1, 2024

OUTSIDE U.S. AND CANADA: This warranty does not apply to, and TRUE is not responsible for, any warranty claims made on products sold or used outside the United States and Canada or purchased in the USA for use in Canada or vice versa.

Warranty may be varied by contract. Customers purchasing under a master purchasing agreement, or similar contract, should see their agreement for applicable warranty terms.*

ENVIRONMENTAL ATTRIBUTES

Any and all environmental attributes, including environmental offset credit rights, with respect to TRUE® refrigeration units manufactured after September 1, 2015, shall remain the property of True Manufacturing Co., Inc. and are not transferred.

KEY PACKET LOCATION

Keys are included inside the envelope. Keep keys out of reach of children.

Las llaves están incluidas en el sobre. Mantenga las llaves fuera del alcance de los niños.

Clés incluses dans l'enveloppe. Tenir hors de portée des enfants.

Schlüssel sind im Umschlag enthalten. Die Schlüssel für Kinder unzugänglich aufbewahren.

Le chiavi sono inserite all'interno della busta. Tenere le chiavi fuori dalla portata dei bambini.

De sleutels zitten in de enveloppe. Bewaar de sleutels buiten het bereik van kinderen.

Klucze znajdują się w kopercie. Trzymać klucze z poza zasięgiem dzieci.

يتم إدراج الأقفال داخل غلاف. يجب الاحتفاظ بالمفاتيح بعيدة عن متناول الأطفال.

The logo for True, featuring the word "True" in a stylized, italicized blue font with a registered trademark symbol.

truemfg.com