



**TRUE FOOD SERVICE EQUIPMENT, INC.**

2001 East Terra Lane • P.O. Box 970 • O'Fallon, Missouri 63366  
 (636)240-2400 • Fax (636)272-2408 • (800)325-6152 • Intl Fax# (001)636-272-7546  
 Parts Dept. (800)424-TRUE • Parts Dept. Fax# (636)272-9471 • www.truemfg.com

Project Name: \_\_\_\_\_

Location: \_\_\_\_\_

Item #: \_\_\_\_\_ Qty: \_\_\_\_\_

Model #: \_\_\_\_\_

A/A #

S/S #

Model:  
**TSSU-27-8D-2**

**Food Prep Table:**  
*Drawered Sandwich/Salad Unit*



**TSSU-27-8D-2**

- ▶ True's salad/sandwich units are designed with enduring quality that protects your long term investment.
- ▶ Oversized, environmentally friendly (134A) patented, forced-air refrigeration system holds 33°F to 41°F (.5°C to 5°C).
- ▶ Complies with and listed under ANSI/NSF-7-1997-6.3.
- ▶ All stainless steel front, top and ends. Matching aluminum finished back.
- ▶ Stainless steel, patented, foam insulated lid and hood keep pan temperatures colder, lock in freshness and minimize condensation. Removable for easy cleaning.
- ▶ 11<sup>3</sup>/<sub>4</sub>" (299 mm) deep, 1/2" (13 mm) thick, full length removable cutting board. Sanitary, high-density, NSF approved white polyethylene provides tough preparation surface.
- ▶ Each drawer accommodates one (1) full size 12" L x 20" W x 6" D (305 mm x 508 mm x 153 mm) food pan (sold separately).
- ▶ Heavy-duty stainless steel drawer slides and rollers.
- ▶ Foamed-in-place, high density polyurethane insulation (CFC free).

**ROUGH-IN DATA**

Specifications subject to change without notice.

Chart dimensions rounded up to the nearest 1/8" (millimeters rounded up to next whole number).

Model	Drawers	Capacity (Cu. Ft.) (liters)	Pans (top)	Cabinet Dimensions (inches) (mm)			HP	Voltage	Amps	NEMA Config.	Cord Length (total ft.) (total m)	Crated Weight (lbs.) (kg)
				L**	D†	H*						
TSSU-27-8D-2	2	6.5 185	8	27 <sup>5</sup> / <sub>8</sub> 702	30 <sup>1</sup> / <sub>8</sub> 766	36 <sup>3</sup> / <sub>4</sub> 934	1/5 1/4	115/60/1 230-240/50/1	4.9 2.9	5-15P ▲	7 2.13	230 105

\*\* Length does not include 1/8" (4 mm) each side for lid pins.

▲ Plug type varies by country.

† Depth does not include 1" (26 mm) for rear bumpers.

\* Height does not include 6 1/4" (159 mm) for castors or 6" (153 mm) for optional legs.



APPROVALS:

AVAILABLE AT:

Model:  
**TSSU-27-8D-2**

**Food Prep Table:**  
*Drawered Sandwich/Salad Unit*



**STANDARD FEATURES**

**DESIGN**

- True's commitment to using the highest quality materials and oversized refrigeration systems provides the user with colder product temperatures, lower utility costs, exceptional food safety and the best value in today's food service marketplace.

**REFRIGERATION SYSTEM**

- Factory engineered, self-contained, capillary tube system using environmentally friendly (CFC free) 134A refrigerant.
- Oversized, factory balanced refrigeration system with guided airflow to provide uniform temperature in food pans and cabinet interior.
- Patented forced-air design holds 33°F to 41°F (.5°C to 5°C) product temperature in food pans and cabinet interior. Complies with and listed under ANSI/NSF-7-1997-6.3.
- Sealed, cast iron, self-lubricating evaporator fan motor(s) and larger fan blades give True sandwich/salad units a more efficient, low velocity, high volume airflow design.
- Condensing unit access in back of cabinet, slides out for easy maintenance.

**CABINET CONSTRUCTION**

- Exterior - stainless steel front, top and ends. Matching aluminum finished back.
- Interior - attractive, NSF approved, white aluminum liner. 300 series stainless steel floor with coved corners.
- Insulation - entire cabinet structure and drawer facings are foamed-in-place using high density, CFC free, polyurethane insulation.
- 5" (127 mm) diameter stem castors - locks provided on front set. 36" (915 mm) work surface height.

**DRAWERS**

- Stainless steel exterior drawer facings and liners. Stainless steel drawer frames.
- Each drawer fitted with 12" (305 mm) long recessed handle that is foamed-in-place with a sheet metal interlock to ensure permanent attachment.
- Heavy-duty stainless steel drawer slides and rollers. Removable without tools for easy cleaning.
- Magnetic drawer gaskets of one piece construction, removable without tools for ease of cleaning.

**DRAWER PAN CAPACITY**

- Each drawer accommodates one (1) full size 12" L x 20" W x 6" D (305 mm x 508 mm x 153 mm) food pan (sold separately). Drawer will support varying size pan configurations with available pan divider bars (drawer pans and divider bars sold separately).

**MODEL FEATURES**

- Evaporator is epoxy coated to eliminate the potential of corrosion.
- 11<sup>3</sup>/<sub>4</sub>" (299 mm) deep, full length removable cutting board. Sanitary, high-density, NSF approved white polyethylene provides tough preparation surface.
- Stainless steel, patented, foam insulated lid and hood keep pan temperatures colder, lock in freshness and minimize condensation. Removable for easy cleaning.
- NSF-7 compliant for open food product.

**PAN CAPACITY**

- Comes standard with 8 (1/6 size) 6<sup>7</sup>/<sub>8</sub>" L x 6<sup>1</sup>/<sub>4</sub>" W x 4" D (175 mm x 159 mm x 102 mm) clear polycarbonate, NSF approved, food pans in countertop prep area.
- Countertop pan opening designed to fit varying size pan configurations with available pan divider bars. Varying size pans supplied by others.

**ELECTRICAL**

- Unit completely pre-wired at factory and ready for final connection to a 115/60/1 phase, 15 amp dedicated outlet. Cord and plug set included.



115/60/1  
NEMA-5-15R

**OPTIONAL FEATURES/ACCESSORIES**

Upcharge and lead times may apply.

- 230 - 240V / 50 Hz.
- 6" (153 mm) standard legs.
- 6" (153 mm) seismic/flanged legs.
- 2<sup>1</sup>/<sub>2</sub>" (64 mm) diameter castors.
- Single overshelf.
- Double overshelf.
- Flat lid.
- Sneezeguard.
- 11<sup>3</sup>/<sub>4</sub>" (299 mm) deep, 1/2" (13 mm) thick, composite cutting board. Requires "L" brackets.
- Crumb catcher. Requires crumb catcher cutting board for proper installation.
- Pan dividers.
- Exterior rectangular digital temperature display (factory installed).
- Plexiglas lid cover.
- ADA compliant models with 34" (864 mm) work surface height.
- Remote cabinets (condensing unit supplied by others; system comes standard with 404A expansion valve and requires R404A refrigerant). Consult factory technical service department for BTU information.

**PLAN VIEW**

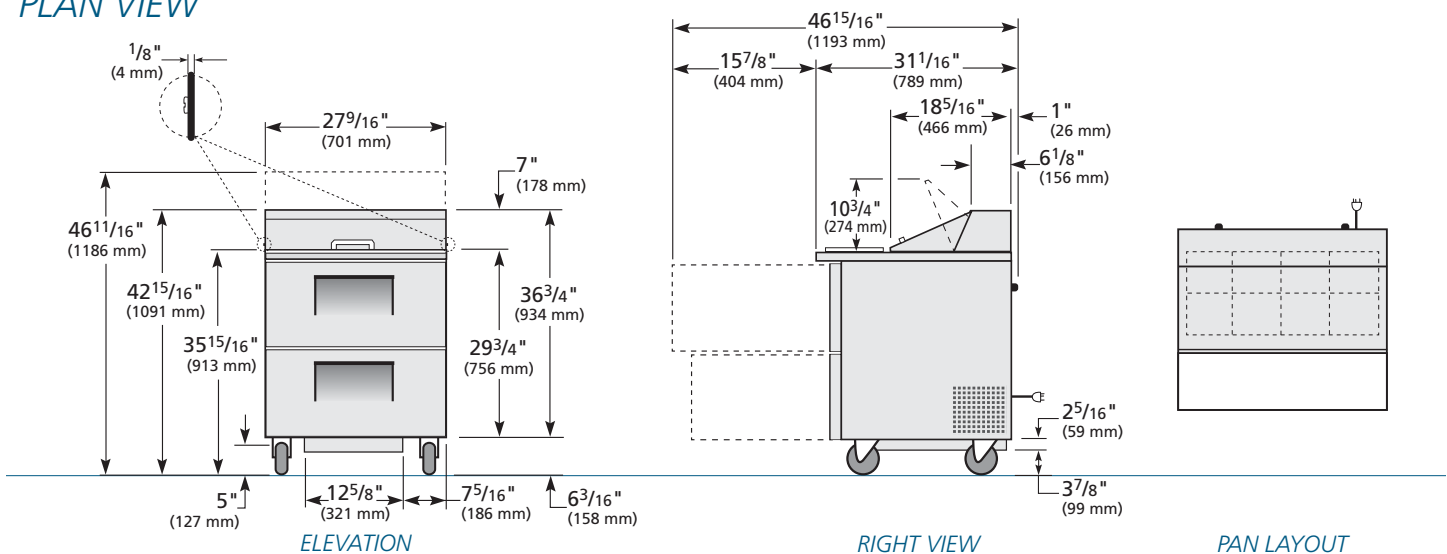

**WARRANTY**  
One year warranty on all parts and labor and an additional 4 year warranty on compressor. (U.S.A. only)

METRIC DIMENSIONS ROUNDED UP TO THE NEAREST WHOLE MILLIMETER  
SPECIFICATIONS SUBJECT TO CHANGE WITHOUT NOTICE



Model	Elevation	Right	Plan	3D
TSSU-27-8D-2	TFNY16E	TFNY16S	TFNY16P	TFNY163

**TRUE FOOD SERVICE EQUIPMENT**