



TRUE FOOD SERVICE EQUIPMENT, INC.

2001 East Terra Lane • P.O. Box 970 • O'Fallon, Missouri 63366
 (636)240-2400 • Fax (636)272-2408 • (800)325-6152 • Intl Fax# (001)636-272-7546
 Parts Dept. (800)424-TRUE • Parts Dept. Fax# (636)272-9471 • www.truemfg.com

Project Name: _____

A/A #

Location: _____

Item #: _____ Qty: _____

SIS #

Model #: _____

Model:
TH-23G

TH Series:
Reach-In Glass Door Heated Cabinet



TH-23G

- ▶ Provides cabinet holding temperature of 80°F to 180°F (26.6°C to 82.2°C).
- ▶ Internal fan provides low velocity, forced-air heat distribution to assure even temperatures throughout the cabinet.
- ▶ Stainless steel, tube heating element for uniform generation of electric heat. Cabinet comes with a total of 850 watts. Heating element sheathed for corrosion resistance.
- ▶ Exterior - 300 series stainless steel front. Anodized quality aluminum exterior ends and back.
- ▶ Interior - 300 series stainless steel interior liner and floor.
- ▶ Energy efficient, triple pane, thermal insulated glass door.
- ▶ Cabinet comes standard with three (3), adjustable, heavy duty chrome plated wire shelves.
- ▶ Entire cabinet structure is foamed-in-place using high density, CFC free, polyurethane insulation.

ROUGH-IN DATA

Specifications subject to change without notice.

Chart dimensions rounded up to the nearest 1/8" (millimeters rounded up to next whole number).

Model	Doors	Capacity (Cu. Ft.) (liters)	Shelves	Cabinet Dimensions (inches) (mm)			Watts	Voltage	Amps	NEMA Config.	Cord Length (total ft.) (total m)	Crated Weight (lbs.) (kg)
				L	D [†]	H*						
TH-23G	1	23 652	3	27 686	29 ³ / ₄ 756	78 ³ / ₈ 1991	850	115/60/1	7.8	5-15P	9 2.74	255 123

[†] Depth does not include 1³/₈" (35 mm) for door handle.

* Height does not include 5" (127 mm) for castors, 6" (153 mm) for optional legs, or 1" (26 mm) for ventilator cap.



9/07

Printed in U.S.A.

APPROVALS:

AVAILABLE AT:

Model:
TH-23G

TH Series:
Reach-In Glass Door Heated Cabinet



STANDARD FEATURES

DESIGN

- True's glass door reach-in heated cabinets are designed with enduring quality that protects your long term investment.

HEATING SYSTEM

- Cabinet is designed to provide holding temperatures of 80°F to 180°F (26.6°C to 82.2°C). Heating system controlled by exterior on/off switch and temperature control dial.
- Stainless steel, tube heating element for uniform generation of electric heat. Cabinet comes with a total of 850 watts. Heating element sheathed for corrosion resistance.
- Low-velocity fans to assure even temperature distribution throughout the cabinet.
- Manually controlled vent located on top of the cabinet for positive humidity control.
- Exterior dial thermometer; accurate, direct reading of internal cabinet temperature.

CABINET CONSTRUCTION

- Exterior - 300 series stainless steel front. Anodized quality aluminum exterior ends and back.
- Interior - 300 series stainless steel interior liner and floor.
- Insulation - entire cabinet structure is foamed-in-place using high density, CFC free, polyurethane insulation.

- Welded, heavy duty galvanized frame rail dipped in rust inhibiting enamel paint for corrosion protection inside and out.
- Frame rail fitted with 4" diameter stem castors - locks provided on front set.

DOORS

- Energy efficient, triple pane thermal insulated glass door assembly with extruded aluminum frame.
- Door fitted with 12" (305 mm) extruded aluminum handle.
- Positive seal self-closing door. Lifetime guaranteed door hinges and torsion type closure system.
- Magnetic door gasket of one piece construction, removable without tools for ease of cleaning.

SHELVING

- Three (3) adjustable, heavy duty chrome plated wire shelves 21⁷/₁₆" L x 23¹/₄" D (545 mm x 591 mm). Four (4) chrome plated shelf clips included per shelf.
- Anodized aluminum shelf support pilasters. Shelves are adjustable on 1/2" (13 mm) increments.

LIGHTING

- Incandescent interior lighting; safety shielded.

MODEL FEATURES

- 12"L x 20"W x 1"D (305 mm x 508 mm x 26 mm) humidity pan standard for contents requiring high humidity.

- True heated cabinets are designed to hold warm baked or cooked food. Cabinets are not designed to heat ambient or cold products.
- NSF-4 compliant for open food product.

ELECTRICAL

- True requires that a sole use circuit be used for the unit.
- Unit completely pre-wired at factory and ready for final connection to a 115/60/1 phase - 15 amp dedicated outlet. Cord and plug set included.



115/60/1
NEMA-5-15R

OPTIONAL FEATURES/ACCESSORIES

Upcharge and lead times may apply.

- 6" (153 mm) standard legs.
- 6" (153 mm) seismic/flanged legs.
- Alternate door hinging (factory installed).
- Additional shelves.

PLAN VIEW

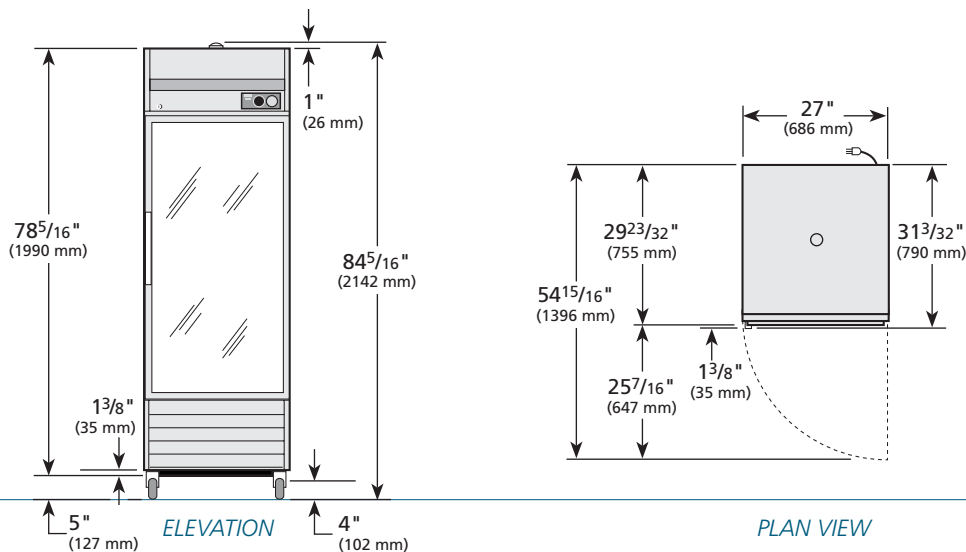

WARRANTY

One year warranty on all parts and labor. (U.S.A. only)

METRIC DIMENSIONS ROUNDED UP TO THE NEAREST WHOLE MILLIMETER
SPECIFICATIONS SUBJECT TO CHANGE WITHOUT NOTICE



Model	Elevation	Right	Plan	3D
TH-23G	TFEY36E	TFEY06S	TFEY06P	TFEY363

TRUE FOOD SERVICE EQUIPMENT