



# TRUE FOOD SERVICE EQUIPMENT, INC.

2001 East Terra Lane • P.O. Box 970 • O'Fallon, Missouri 63366  
(636)240-2400 • Fax (636)272-2408 • (800)325-6152 • Intl Fax# (001)636-272-7546  
Parts Dept. (800)424-TRUE • Parts Dept. Fax# (636)272-9471 • www.truemfg.com

Project Name: \_\_\_\_\_

A/A #

Location: \_\_\_\_\_

Item #: \_\_\_\_\_ Qty: \_\_\_\_\_

SIS #

Model #: \_\_\_\_\_

Model:  
**TBB-24-60G-SD**

## 24" Back Bar Cooler: Glass Slide Door



### TBB-24-60G-SD

- ▶ True's refrigerated back bar coolers are designed with enduring quality and value. Our commitment to using the highest quality materials and oversized refrigeration assures colder product temperatures and years of trouble free service.
- ▶ Oversized, factory balanced, refrigeration system holds 33°F to 38°F (.5°C to 3.3°C).
- ▶ Exterior - heavy duty, wear resistant laminated black vinyl front and sides. Matching black aluminum back. All stainless steel counter top.
- ▶ Interior - 300 series stainless steel floor with 1/2" (13 mm) reinforced lip and heavy gauge galvanized steel walls.
- ▶ NSF approved for packaged and bottled product.
- ▶ Self-closing, positive seal doors.
- ▶ "Low-E", double pane thermal glass door assemblies. The latest in energy efficient technology.
- ▶ Entire cabinet structure is foamed-in-place using high density, CFC free, polyurethane insulation.

### ROUGH-IN DATA

Specifications subject to change without notice.

Chart dimensions rounded up to the nearest 1/8" (millimeters rounded up to next whole number).

Model	Doors	Capacity		Shelves	Cabinet Dimensions (inches) (mm)			HP	Voltage	Amps	NEMA Config.	Cord Length (total ft.) (total m)	Crated Weight (lbs.) (kg)
		12 oz. Cans	1/2 Barrels		L	D†	H						
TBB-24-60G-SD	2	104 6-pks	3	4	61 1/8 1553	23 7/8 607	35 5/8 905	1/3	115/60/1	7.0	5-15P	7 2.4	n/a n/a

† Depth does not include 1" (26 mm) for rear bumpers.

6/07 Printed in U.S.A.

APPROVALS:

AVAILABLE AT:

Model:  
**TBB-24-60G-SD**

## 24" Back Bar Cooler: Glass Slide Door



### STANDARD FEATURES

#### DESIGN

- True's refrigerated back bar coolers are designed with enduring quality and value. Our commitment to using the highest quality materials and oversized refrigeration assures colder product temperatures and years of trouble free service.

#### REFRIGERATION SYSTEM

- Factory engineered, self-contained, capillary tube system using environmentally friendly (CFC free) 134A refrigerant.
- Extra large evaporator coil balanced with higher horsepower compressor and large condenser; maintains cabinet temperatures of 33°F to 38°F (.5°C to 3.3°C).
- Sealed, cast iron, self-lubricating evaporator fan motor(s) and larger fan blades give True merchandisers a more efficient low velocity, high volume airflow design. This unique design ensures faster temperature pull down of warm product, colder holding temperatures and faster recovery in high use situations.
- Condensing unit accessed from behind front grill, slides out for easy cleaning and maintenance.

#### CABINET CONSTRUCTION

- Exterior - heavy duty, wear resistant laminated black vinyl front and sides. Matching black aluminum back. All stainless steel counter top.
- Interior - 300 series stainless steel floor with 1/2" (13 mm) reinforced lip and heavy gauge galvanized steel walls.

- Insulation - entire cabinet structure is foamed-in-place using high density, CFC free, polyurethane insulation.
- Welded, heavy duty galvanized base rail dipped in rust inhibiting enamel paint for corrosion protection inside and out.

#### DOORS

- "Low-E", double pane thermal glass door assemblies. The latest in energy efficient technology.
- Each door fitted with 12" (305 mm) long handle.
- Self-closing doors. Counter-balanced weight system for smooth, even, positive closing.

#### SHELVING

- Four (4) adjustable, heavy duty, black PVC coated wire shelves 23 1/4" L x 16 1/4" D (591 mm x 413 mm). Four (4) chrome plated shelf clips included per shelf.
- Aluminum shelf support pilasters. Shelves are adjustable on 1/2" (13 mm) increments.

#### LIGHTING

- Fluorescent interior lighting. Safety shielded.
- Cabinet lighting utilizes electronic ballast and T-8 bulbs for brighter illumination, longer bulb life and increased energy efficiency.

#### MODEL FEATURES

- Evaporator is epoxy coated to eliminate the potential of corrosion.
- Designed to accommodate a variety of beer kegs. Doors must be removed to place 1/2 barrels in cabinet and then reinstalled.

- Listed under NSF-7 for the storage and/or display of packaged or bottled product.

#### ELECTRICAL

- Unit completely pre-wired at factory and ready for final connection to a 115/60/1 phase, 15 amp dedicated outlet. Cord and plug set included.



115/60/1  
NEMA-5-15R

#### OPTIONAL FEATURES/ACCESSORIES

Upcharge and lead times may apply.

- 6" (153 mm) standard legs.
- 6" (153 mm) seismic/flanged legs.
- 2 1/2" (64 mm) diameter castors.
- 4" (102 mm) diameter castors.
- Additional shelves.
- TrueTrac one liter or wine bottle organizers.
- TrueTrac 12oz. (355ml) bottle organizers.
- Ratchet locks.
- Remote cabinets (condensing units supplied by others; system comes standard with 404A expansion valve and requires R404A refrigerant). Consult factory technical service department for BTU information.

### PLAN VIEW

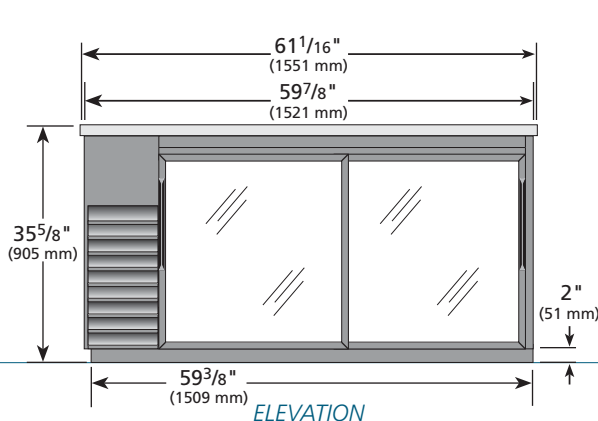

ELEVATION

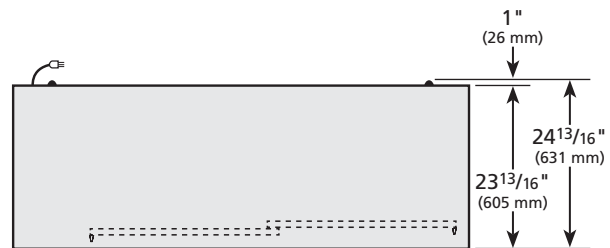

PLAN VIEW

#### WARRANTY

One year warranty on all parts and labor and an additional 4 year warranty on compressor. (U.S.A. only)

METRIC DIMENSIONS ROUNDED UP TO THE NEAREST WHOLE MILLIMETER  
SPECIFICATIONS SUBJECT TO CHANGE WITHOUT NOTICE



Model	Elevation	Right	Plan	3D
TBB-24-60G-SD				

### TRUE FOOD SERVICE EQUIPMENT