



TRUE FOOD SERVICE EQUIPMENT, INC.

2001 East Terra Lane • P.O. Box 970 • O'Fallon, Missouri 63366
 (636)240-2400 • FAX (636)272-2408 • (800)325-6152 • www.truemfg.com
 Parts Dept. (800)424-TRUE • Parts Dept. FAX# (636)272-9471

Project Name: _____

A/A #

Location: _____

Item #: _____ Qty: _____

SIS #

Model #: _____

Model:
GDM-7F

Glass Door Merchandiser:
Swing Door Freezer



GDM-7F

- ▶ The world's #1 manufacturer of glass door merchandisers.
- ▶ Designed using the highest quality materials and components to provide the user with an attractive, point of purchase merchandiser that brilliantly displays frozen food and ice cream, resulting in high impulse sales.
- ▶ Oversized, factory balanced, refrigeration system holds -10°F (-23.3°C). Ideal for ice cream and frozen food products.
- ▶ Exterior - non-peel or chip white laminated vinyl; durable and permanent.
- ▶ Interior - attractive, NSF approved, white aluminum interior liner with 300 series stainless steel floor.
- ▶ Self closing door. Positive seal, torsion type closure system.
- ▶ Triple pane thermal glass door assembly with extruded aluminum frame.
- ▶ Entire cabinet structure is foamed-in-place using high density, CFC free, polyurethane insulation.

ROUGH-IN DATA

Specifications subject to change without notice.

Chart dimensions rounded up to the nearest 1/8" (millimeters rounded up to next whole number).

Model	Doors	Capacity (Cu. Ft.) (liters)	Shelves	Cabinet Dimensions (inches) (mm)			HP	Voltage	Amps	NEMA Config.	Cord Length (total ft.) (total m)	Crated Weight (lbs.) (kg)
				L	D†	H						
GDM-7F	1	7 199	3	24 610	24 ³ / ₄ 629	39 ³ / ₄ 1010	1/2 1/3	115/60/1 230-240/50/1	11.1 4.7	5-15R ▲	9 2.74	220 100

† Depth does not include 1³/₈" (35 mm) for door handle.

▲ Plug type varies by country.



APPROVALS:

AVAILABLE AT:

Model:
GDM-7F

Glass Door Merchandiser:
Swing Door Freezer



STANDARD FEATURES

DESIGN

- True's glass door freezers are designed with enduring quality that protects your long term investment.
- True's commitment to using the highest quality materials and oversized refrigeration systems provides the user with colder product temperatures, and lower utility costs in an attractive merchandiser that brilliantly displays frozen food and ice cream.

REFRIGERATION SYSTEM

- Factory engineered self-contained, capillary tube system using environmentally friendly (CFC free) R404A refrigerant.
- Extra large evaporator coil balanced with higher horsepower compressor and large condenser; maintains -10°F (-23.3°C).
- Sealed, cast iron, self-lubricating evaporator fan motor(s) and larger fan blades give True merchandisers a more efficient low velocity, high volume airflow design. This unique design ensures colder standard temperatures and faster recovery in high use situations.
- Automatic defrost system time-initiated, time-terminated.

CABINET CONSTRUCTION

- Exterior - non-peel or chip white laminated vinyl; durable and permanent.
- Interior - attractive, NSF approved, white aluminum liner with 300 series stainless steel floor.

- Insulation - entire cabinet structure is foamed-in-place using high density, CFC free, polyurethane insulation.
- Cabinet fitted with 2 1/2" (64 mm) legs.
- Back-lit door sign decal. Variety of decal options available.

DOOR

- Triple pane thermal glass door assembly with extruded aluminum frame.
- Door fitted with 15" (381 mm) extruded handle.
- Self closing door. Positive seal, torsion type closure system.
- Magnetic door gasket of one piece construction, removable without tools for ease of cleaning.

SHELVING

- Three (3) adjustable, heavy duty PVC coated wire shelves. Two (2) top shelf dimensions are 19 11/16" x 17" D (501 mm x 432 mm). One (1) bottom shelf dimension is 19 11/16" L x 9 1/4" D (501 mm x 235 mm). Four (4) chrome plated shelf clips included per shelf.
- Shelf support pilasters made of same material as cabinet interior; shelves are adjustable on 1/2" (13 mm) increments.

LIGHTING

- Safety shielded fluorescent interior lighting.
- Cabinet lighting utilizes electronic ballast and T-8 bulbs for brighter illumination, longer bulb life and increased energy efficiency.

MODEL FEATURES

- Evaporator is epoxy coated to eliminate the potential of corrosion.

- See our website www.truemfg.com for latest color and decal offerings.
- Backguard and floor rack ensures optimum airflow.
- Listed under NSF-7 for the storage and/or display of packaged or bottled product.

ELECTRICAL

- Unit completely pre-wired at factory and ready for final connection to a 115/60/1 phase - 15 amp dedicated outlet. Cord and plug set included.



115/60/1
NEMA-5-15R

OPTIONAL FEATURES/ACCESSORIES

Upcharge and leads times may apply.

- 230-240V / 50Hz.
- Black exterior.
- Rosewood exterior.
- Stainless exterior.
- Black aluminum interior liner with black shelving.
- 1 1/4" (32 mm) pricing strips.
- Novelty baskets.

PLAN VIEW

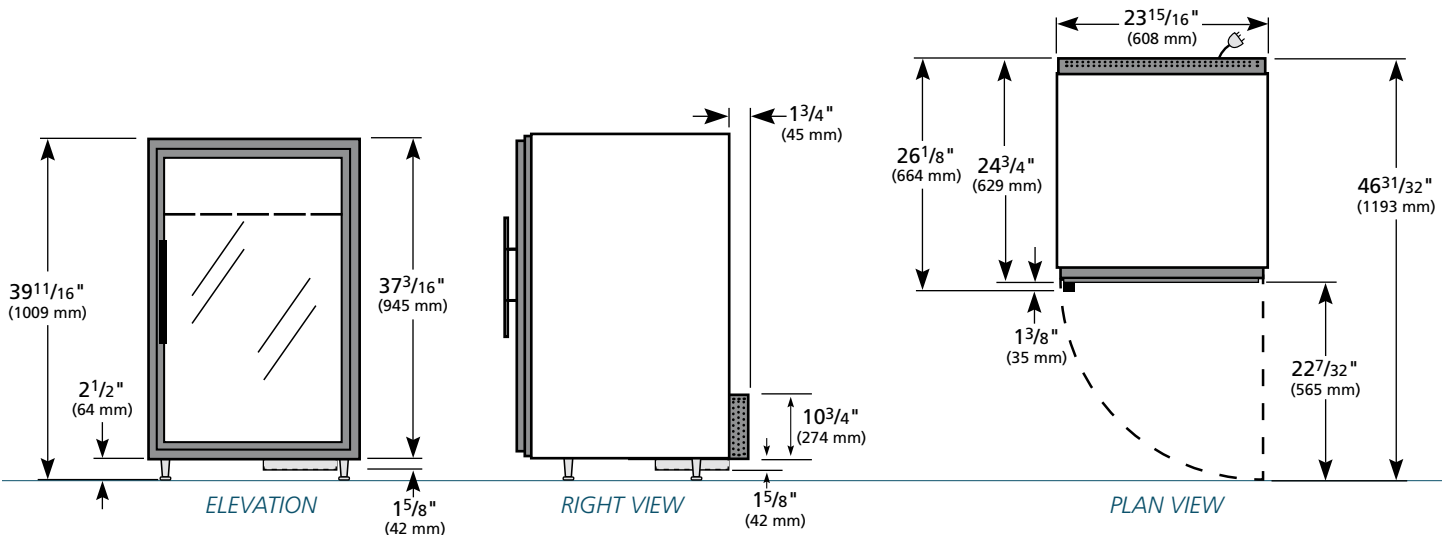

WARRANTY
 One year warranty on all parts & labor and an additional 4 year warranty on compressor. (U.S.A. only)

METRIC DIMENSIONS ROUNDED UP TO THE NEAREST WHOLE MILLIMETER
 SPECIFICATIONS SUBJECT TO CHANGE WITHOUT NOTICE



Model	Elevation	Right	Plan	3D
GDM-7F	TFD033E	TFD033S	TFD033P	TFD0333

TRUE FOOD SERVICE EQUIPMENT